

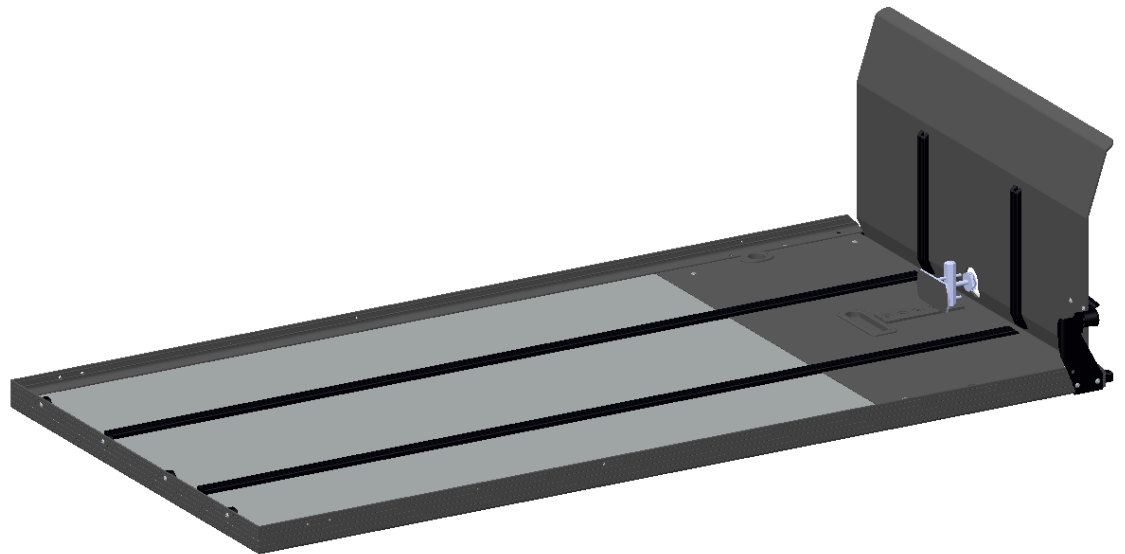

**Cargo Management
Products**

INSTALLATION INSTRUCTIONS & PARTS LIST

SS150 SINGLE DECK for:
Chevrolet Suburban
GMC Yukon XL



*Link Mfg. Ltd.
223 15th St. N.E.
Sioux Center, IA USA
51250-2120*

*(712) 722-4868
Fax (712) 722-4779*

**QUESTIONS?
CALL CUSTOMER
SERVICE
1-800-248-3057
www.linkcmp.com**

This **Link SS150** fits 1992 and newer Chevy/GMC Suburbans.

Estimated weight: 135 lbs.

1. Introduction

Thank you for choosing a Link Cargo Management Products (CMP) SS150/SS150XL single deck system. We want to help you to get the best results from the deck and to operate it safely. This manual contains information to introduce you to the Link CMP SS150/SS150XL and to assist you with its installation. This manual is intended solely for use with this product.

All information in this manual is based on the latest information available at the time of printing. Link reserves the right to change its products or manuals at any time without notice. Contact Link CMP at (800) 248-3057 for information on recent changes to products.

Defective or damaged components should be returned to Link with a pre-arrange Returned Goods Authorization (RGA) number through the Customer Service department. The defective or damaged component(s) may then be replaced if in compliance with warranty conditions.

Review the **Parts Lists** on **Pages 8-12** to become familiar with the different components of the **SS150**. Be sure all items were included before beginning installation. A deck, hardware kit, bier pin, and ramp kit should be included.

2. Installation

2.1 The **SS150** is shipped with the bier pin and hardware kit attached to the deck. Remove these items and set aside for later use.

2.2 The ramp assembly is installed backwards for shipping. To remove the ramp, position it in the raised position. One side of the ramp is held in place with a pressure-fit while the other is contained. Remove the ramp by carefully lifting the ramp up until the hinge disengages. Slide the ramp away from the other hinge to disengage the ramp from the deck. Reverse and reinstall the ramp assembly as shown on Page 1.

2.3 **On 1994-2006 vehicle models**, remove the rear seats, and fold the middle seats per the owners manual.

2.3.1 The SS150 is held down using existing fastener holes from the cargo hold-downs. Remove the cargo hold-downs and their fasteners using the supplied Torx key. Place in a labeled bag and store in appropriate location for later use. **(FIG. 2)**

2.3.2 Position the deck inside the vehicle with approximately a 1" gap between the rear of the deck and the seal lip on the door frame. Center the deck between the wheel wells. Align the mounting holes in the rear portion of the deck with the cargo loop mount holes in the vehicle's floor.

2.3.3 Verify the deck location by checking the *ramp assembly* for function. Check for fit with the bumper and verify clearance with all parts of the vehicle. Re-position the deck if needed.

2.3.4 Secure the deck by inserting the supplied button head screws through the deck and into the cargo loop mount holes in the vehicle floor. Tighten the fasteners using the supplied hex key.

2.3.5 Recheck the *ramp assembly* for proper operation.



2. Installation (cont)

2.4 On 2007-2014 model year vehicles,

One front support is needed to compensate for a height variation between the second and third rows. Install the support at the front of the deck using the fasteners supplied in the hardware kit (71353001).

2007-2014 model year vehicles require the removal of both rows of rear seats.

- 2.4.1 Remove the third row per the owners manual.
- 2.4.2 To remove the second row, fold the seat into it's stored position per the owners manual.
- 2.4.3 The base of the seat has a carpet-covered cover held in place by Velcro strips. Remove the cover by lifting up and to the rear. This will expose the base of the seat. (**FIG. 3**)
- 2.4.4 Remove the eight nuts (four per side) securing the seat using a 3/4" socket. Place the nuts in a labeled bag and store In an appropriate location for later use in the event of removal of the deck and re-installation of the seats.
- 2.4.5 Return the seat to the down position but with the seat back folded. Remove the seat by lifting straight up on the base and extracting the unit out the vehicle door.

NOTE: that if the vehicle is equipped with a bench seat, the seat will need to be extracted out the rear of the vehicle.

- 2.4.6 The SS150 is held down using existing fastener holes from the cargo hold-downs. Remove the cargo hold-downs and their fasteners using the supplied Torx key. Place in a labeled bag and store in appropriate location f or later use.
- 2.4.7 Position the deck inside the vehicle with approximately a 1" gap between the rear of the deck and the seal lip on the door frame. Center the deck between the wheel wells. Align the mounting holes in the rear portion of the deck with the cargo loop mount holes in the vehicle's floor.

- 2.4.8 Verify the deck location by checking the *ramp assembly* for function. Check for fit with the bumper and verify clearance with all parts of the vehicle. Re-position the deck if needed.
- 2.4.9 Secure the deck by inserting the supplied button head screws through the deck and into the cargo loop mount holes in the vehicle floor. Tighten the fasteners using the supplied hex key.
- 2.4.10 Recheck the *ramp assembly* for proper operation.

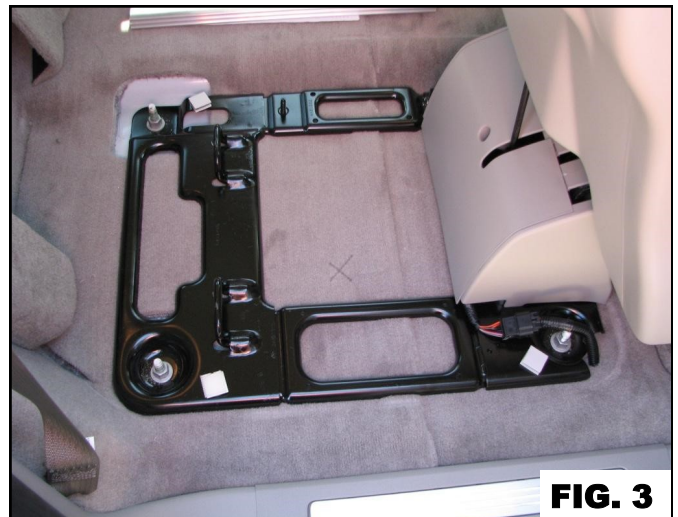

2. Installation (cont)

2.5 On 2015-2020 model year vehicles with seats installed,

A support channel needs to be installed in the rear cargo area with fasteners supplied in kit (71351011).

The rear cargo organizer will need to be removed .

- 2.5.1 Open the organizer, remove the cargo partitions, lift the two rubber mats at the bottom of the organizer, remove the two fasteners, and lift and remove cargo organizer. **(FIG. 4 / FIG. 5)**
- 2.5.2 Center the rear mount assembly in the rear cargo area with arrow facing forward, align over the infloor nuts. Using a 13mm socket tighten the two M8 X 1.25 X 20 hex bolts into place.
- 2.5.3 Slide the SS150 into the rear of the vehicle. Align forward most holes with the rear mount assembly. Tighten the two M 10 X 1.5 X 80 button head screws to using th 6mm hex key supplied. **(FIG. 6)**
- 2.5.10 Recheck the *ramp assembly* for proper operation.



FIG. 4



FIG. 5

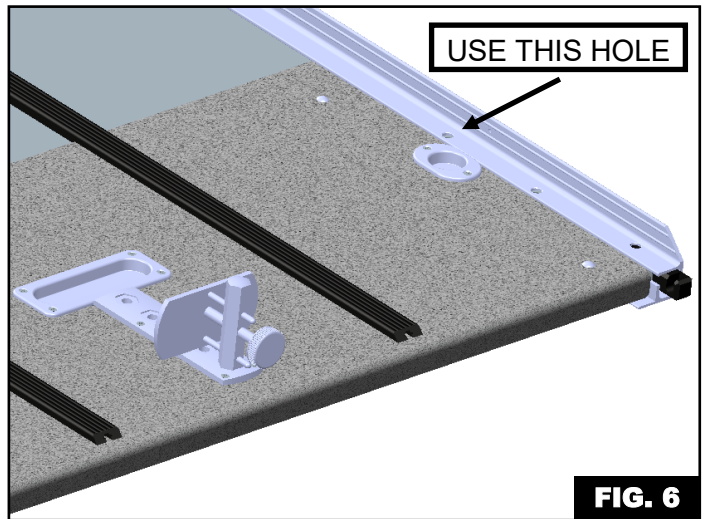

FIG. 6

2. Installation (cont)

2.6 On 2015-2020 model year vehicles with seats removed,

One front support is needed to compensate for a height variation between the second and third rows. Install the support at the front of the deck using the fasteners supplied in the hardware kit (71353001).

2007-2014 model year vehicles require the removal of both rows of rear seats.

- 2.6.1 Open the organizer, remove the cargo partitions, lift the two rubber mats at the bottom of the organizer, remove the two fasteners, and lift and remove cargo organizer. (FIG. 7 / FIG. 8)



- 2.6.2 Remove the third row seats remove the eight 19mm bolts. Remove the seat by lifting straight up on the base and extracting the unit out the rear vehicle hatch.

- 2.6.3 To remove the second row, fold the seat into it's stored position per the owners manual.

- 2.6.4 The base of the seat has a carpet-covered cover held in place by Velcro strips. Remove the cover by lifting up and to the rear. This will expose the base of the seat. (FIG. 9)

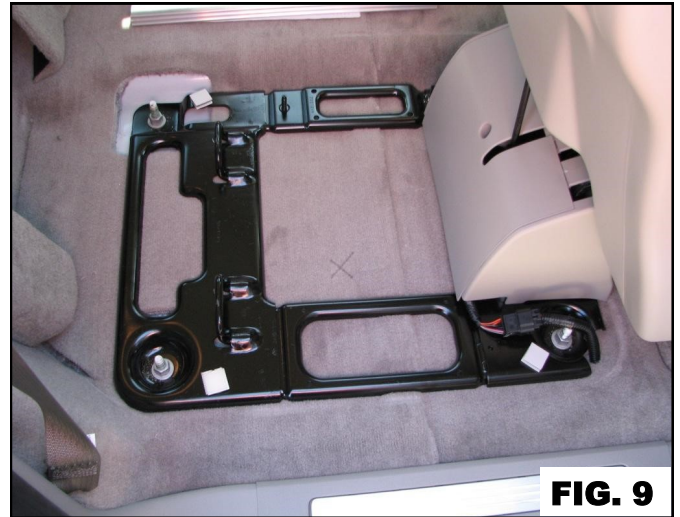

- 2.6.5 Remove the eight nuts (four per side) securing the seat using a 19mm socket. Place the nuts in a labeled bag and store in an appropriate location for later use in the event of removal of the deck and re-installation of the seats.

2. Installation (cont)

- 2.6.6 Return the seat to the down position but with the seat back folded. Remove the seat by lifting straight up on the base and extracting the unit out the vehicle door.

NOTE: that if the vehicle is equipped with a bench seat, the seat will need to be extracted out the rear of the vehicle.

- 2.6.7 The SS150 is held in place using the existing seat fasteners and 12mm nuts. **(FIG. 10)**

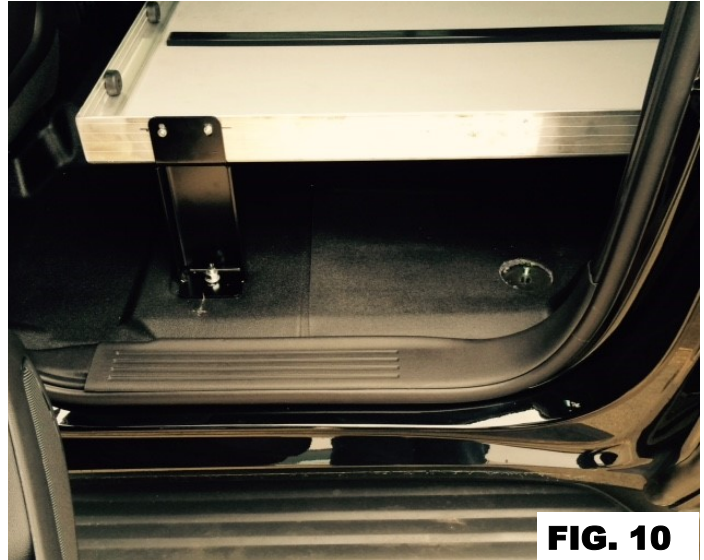

2.7 On 2021 and newer model year vehicles.

A support bracket needs to be installed in the place of the rear cargo organizer (71353008).

The rear cargo organizer will need to be removed.

- 2.7.1 Open the organizer, remove the four fasteners, and lift and remove the cargo organizer. **(FIG.11)**
- 2.7.2 Place (1) 1/2" washer around each of the four cargo organizer studs to distribute the weight of the deck across the vehicle floor.
- 2.7.3 Position the mount bracket on the four studs. Place (1) 1/4" washer, (1) 6mm lock washer, and (1) 6mm nut on each stud. Do not over tighten the nuts.
- 2.7.4 Position the deck into the vehicle. Using the middle mount hole, secure to the mount bracket using (2) 3/8" bolts and (2) 3/8" flange bolts. **(FIG. 12)**

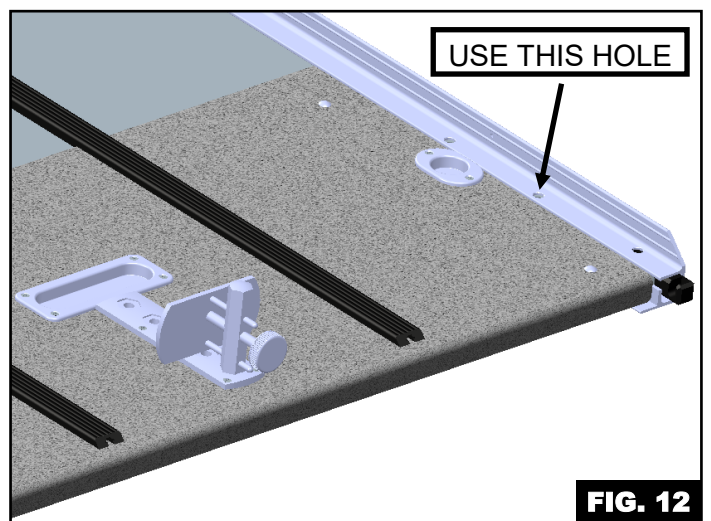

3. Maintenance

- The SS150 is designed for years of trouble-free operation with minimal maintenance. Regular cleaning of surfaces should be completed using soap and water or window cleaner.

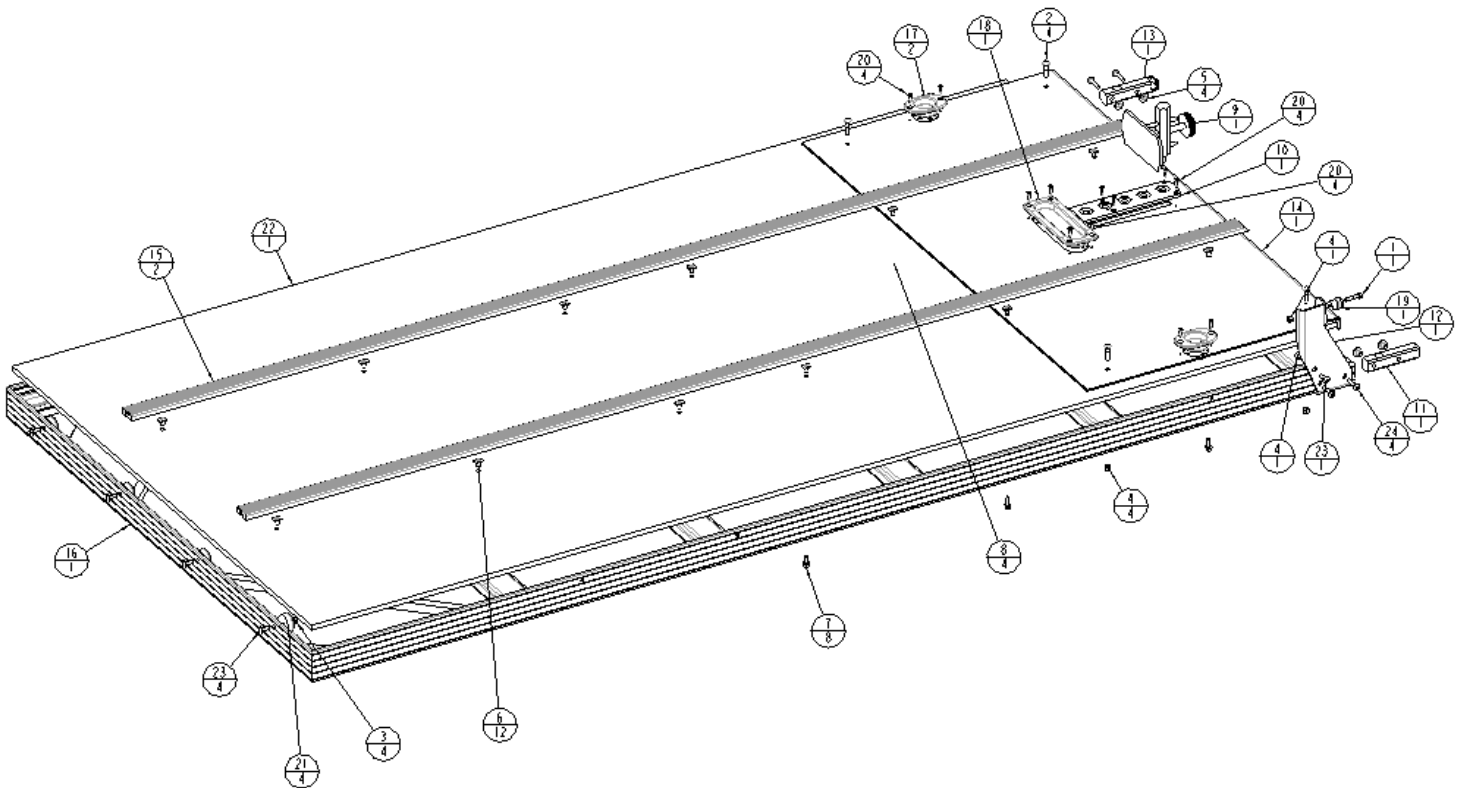

PARTS LIST FOR SS150 SINGLE DECK (7135X004)

ITEM	PART #	DESCRIPTION	QTY	ITEM	PART #	DESCRIPTION	QTY
1	1401-0810	1/4 X 1 1/4 UNC HEX CAP SCR (GR 5)	1	13	7000-0061	TUBE-MOUNT, RAMP	1
2	1435-0810	1/4 X 1 1/4 UNC RND HD SQ NK BOLT GR 5	4	14	7135-0019	REAR ANGLE GUARD	1
3	1470-0800	1/4 UNC HEX NUT (GR B)	4	15	7135-0021	GLIDE STRIP	2
4	1478-0800	1/4 UNC HEX NYLOCK NUT (GR B)	6	16	7135-1000	DECK WELDMENT	1
5	1484-0801	NUT 1/4-20 X 7/16 HT PROPELLER TEE	4	17	7800-0011	RECESSED COT CUP	2
6	1484-0808	1/4-20 X 7/16 SLAB BASE WELD NUT	12	18	7800-0016	SUPER SIZED RECESSED COT CUP	1
7	1506-0420	1/4 X 5/8 FLANGE HEAD BOLT	8	19	15000006	RAMP HOLDER, MALE END	1
8	1506-0421	1/4 X 3/4 FLANGE HEAD BOLT	4	20	15060048	#10 X 3/4 SS FLAT HD TAP SCR	12
9	1507-0293	BIER PIN-ADJUSTABLE	1	21	15070408	BUMPER-RUBBER, NOTCHED	4
10	1507-0295	BIER PIN PLATE (5 HOLE)	1	22	71350006	DECK BOARD	1
11	7000-0027	TUBE-MOUNT, RAMP	1	23	144C-0806	1/4 X 3/4 UNC TRUSS HD PH MACH SCR, SS	5
12	7000-0028	BRACKET-STOP, RAMP	1	24	144C-0810	1/4 X 1 1/4 UNC TRUSS HD PH MACH SCR, SS	4

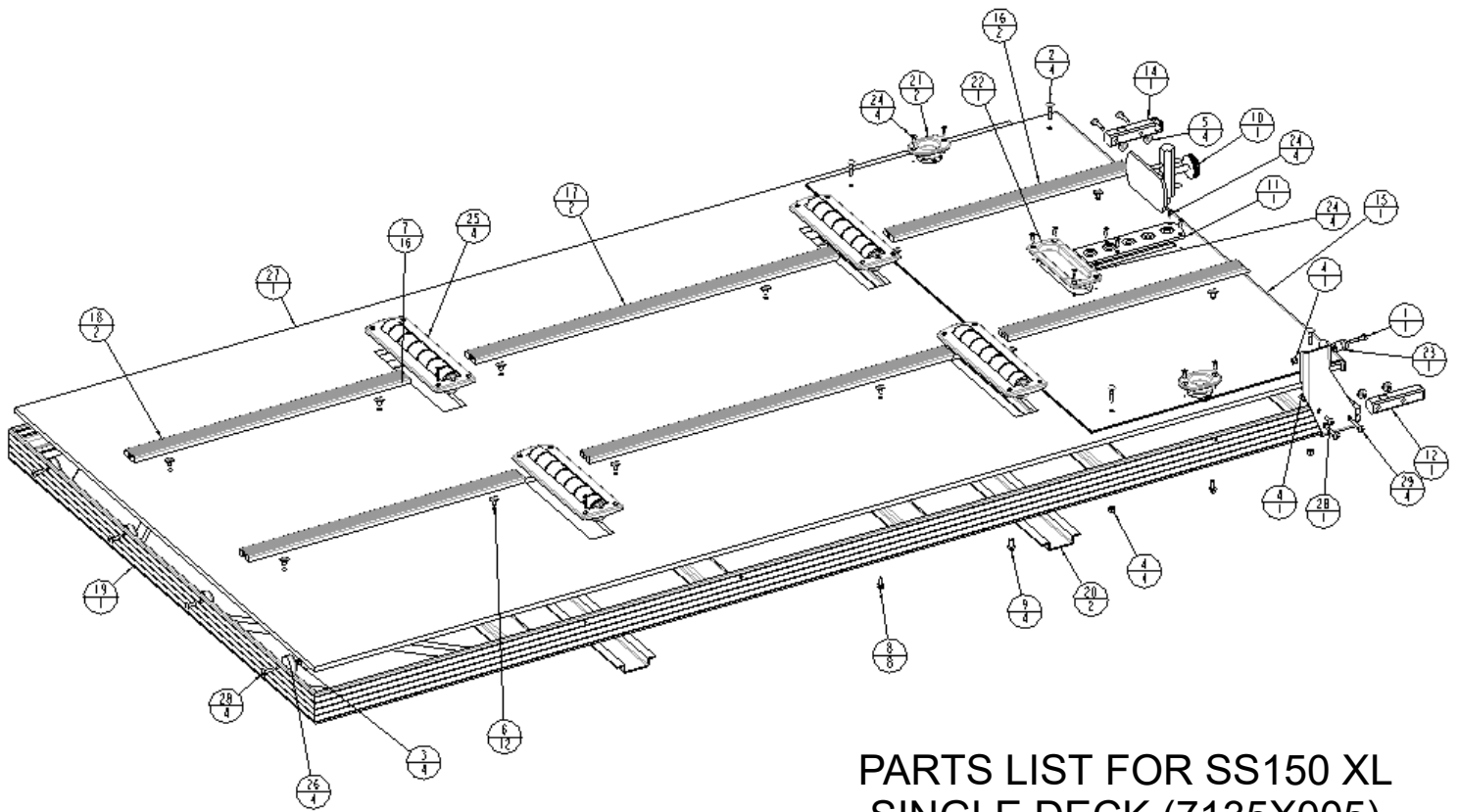

PARTS LIST FOR SS150 XL SINGLE DECK (7135X005)

ITEM	PART #	DESCRIPTION	QTY	ITEM	PART #	DESCRIPTION	QTY
1	1401-0810	1/4 X 1 1/4 UNC HEX CAP SCR (GR 5)	1	16	7135-0022	GLIDE STRIP	2
2	1435-0810	1/4 X 1 1/4 UNC RND HD SQ NK BOLT GR 5	4	17	7135-0023	GLIDE STRIP	2
3	1470-0800	1/4 UNC HEX NUT (GR B)	4	18	7135-0024	GLIDE STRIP	2
4	1478-0800	1/4 UNC HEX NYLOCK NUT (GR B)	6	19	7135-1000	DECK WELDMENT	1
5	1484-0801	NUT 1/4-20 X 7/16 HT PROPELLER TEE	4	20	7135-1007	FLOOR SPLICE	2
6	1484-0808	1/4-20 X 7/16 SLAB BASE WELD NUT	12	21	7800-0011	RECESSED COT CUP	2
7	1506-0043	#10 X 1 SS FLAT HD TYPE B TAP SCR	16	22	7800-0016	SUPER SIZED RECESSED COT CUP	1
8	1506-0420	1/4 X 5/8 FLANGE HEAD BOLT	8	23	15000006	RAMP HOLDER, MALE END	1
9	1506-0421	1/4 X 3/4 FLANGE HEAD BOLT	4	24	15060048	#10 X 3/4 SS FLAT HD TAP SCR	12
10	1507-0293	BIER PIN-ADJUSTABLE	1	25	15070299	CR60 CASKET ROLLER	4
11	1507-0295	BIER PIN PLATE (5 HOLE)	1	26	15070408	BUMPER-RUBBER, NOTCHED	4
12	7000-0027	TUBE-MOUNT, RAMP	1	27	71350015	DECK BOARD	1
13	7000-0028	BRACKET-STOP, RAMP	1	28	144C-0806	1/4 X 3/4 UNC TRUSS HD PH MACH SCR, SS	5
14	7000-0061	TUBE-MOUNT, RAMP	1	29	144C-0810	1/4 X 1 1/4 UNC TRUSS HD PH MACH SCR, SS	4
15	7135-0019	REAR ANGLE GUARD	1				

**PARTS LIST FOR 1992-2014 SUBURBAN HARD-
WARE KIT (71353001)
(NOT SHOWN)**

ITEM	PART #	DESCRIPTION	QTY
1	15060432	M10 X 1.5 X 100 SOCKET BUTTON HD SCREW	2
2	70000109	BRACKET-SUPPORT, 7	1
3	71353101	INSTRUCTIONS-INSTALLATION	1
4	144C-0806	1/4 X 3/4 UNC TRUSS HD PH MACH SCR, SS	2
5	1478-0800	1/4 UNC HEX NYLOCK NUT (GR B)	2
6	1504-0204	KEY-T45 TORX	1
7	1504-0207	KEY-6 MM HEX	1

**PARTS LIST FOR 2015 - 2020 SUBURBAN WITH
SEATS INSTALLED HARDWARE KIT (71351011)
(NOT SHOWN)**

ITEM	PART #	DESCRIPTION	QTY
1	71351009	MOUNT ASSEMBLY- REAR, SS150	1
2	71353101	INSTRUCTIONS-INSTALLATION	1
3	141E0804	HEX FLNG SCR M8X1.25X20 CLS 8.8	2
4	1504-0207	KEY-6 MM HEX	1
5	1506-0001	M10 X 1.5 X 80 BUTTON HD SOCKET SCREW	2

**PARTS LIST FOR 2015 - 2020 SUBURBAN WITH
SEATS REMOVED HARDWARE KIT (71353005)
(NOT SHOWN)**

ITEM	PART #	DESCRIPTION	QTY
1	14761209	HEX NYLON INSERT LOCK NUT, M12 X 1.75, CLASS 10	2
2	14870800	1/4 TYPE A PLAIN WASHER	4
3	14871600	1/2 TYPE A PLAIN WASHER	2
4	71350011	MOUNT-SEAT BRACKET, SS150	2
5	1444-0806	1/4 X 3/4 UNC PHIL HD CSK MACH SCR	4
6	1476-0800	1/4 UNC HEX CTR LOCK NUT (GR B)	4

1992-2020 SUBURBAN RAMP KIT (71352109)

ITEM	PART #	DESCRIPTION	QTY
1	1401-1004	5/16 X 1/2 UNC HEX CAP SCR (GR 5)	1
2	144C-0804	1/4 X 1/2 UNC TRUSS HD PH MACH SCR, SS	6
3	144C-0806	1/4 X 3/4 UNC TRUSS HD PH MACH SCR, SS	2
4	1478-0800	1/4 UNC HEX NYLOCK NUT (GR B)	2
5	14870800	1/4 TYPE A PLAIN WASHER	2
6	15000007	RAMP HOLDER, FEMALE END	1
7	15060054	1/4-20 X 1/4 SLAB BASE WELD NUT	6
8	7000-0035	BRACKET-STOP, RAMP	1
9	71352016	GLIDE STRIP	2
10	71352108	RAMP WELDMENT	1

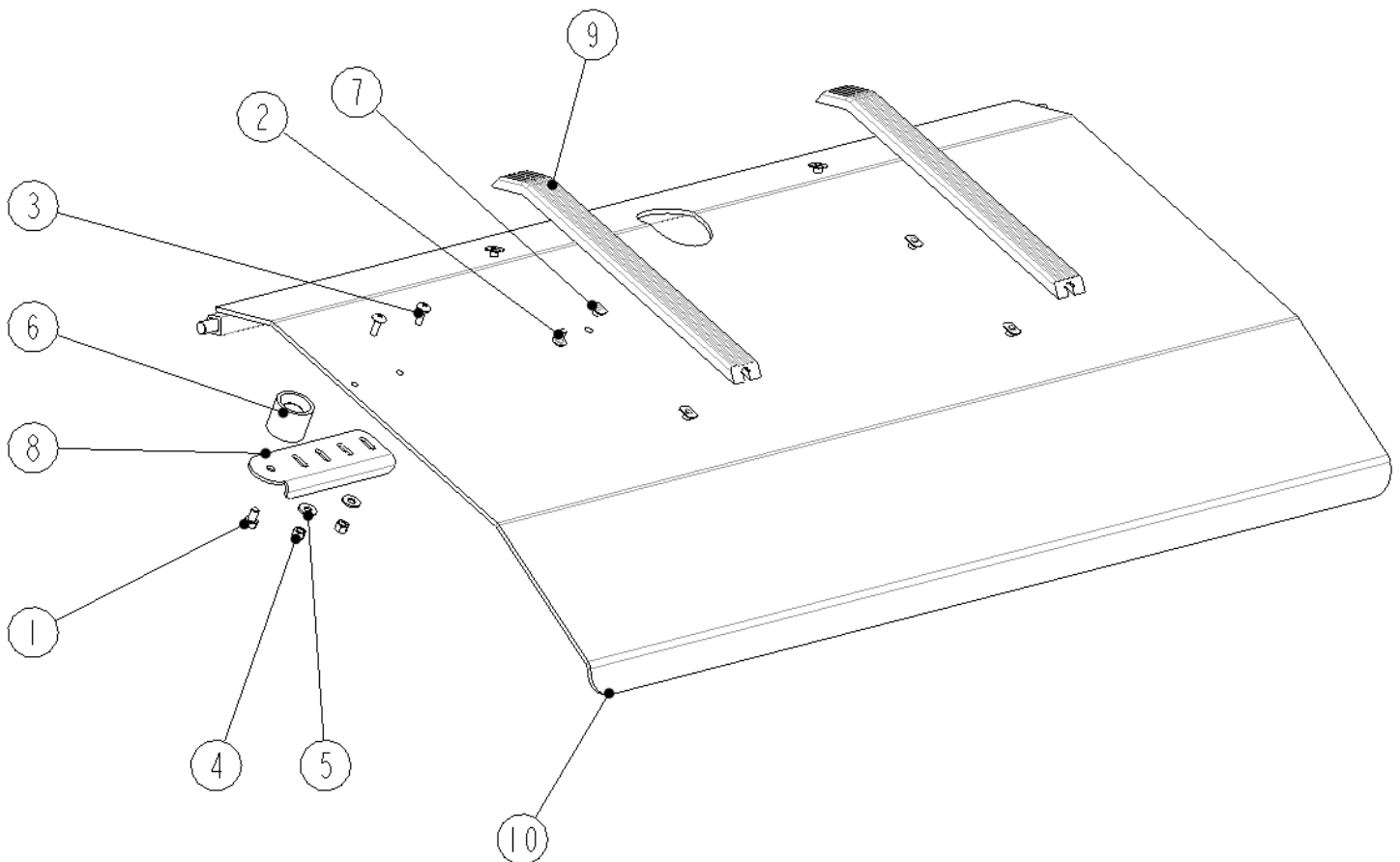

PARTS LIST FOR 2021+ SUBURBAN RAMP KIT (71352114) AND HARDWARE KIT (71353008)

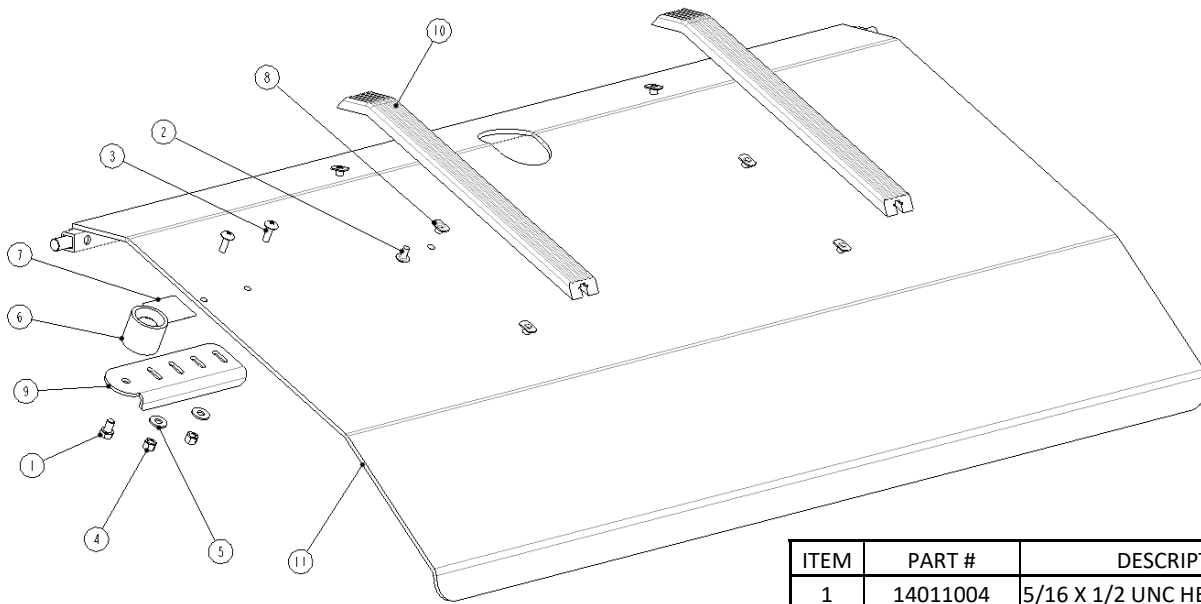

ITEM	PART #	DESCRIPTION	QTY
1	14011004	5/16 X 1/2 UNC HEX CAP SCR	1
2	144C0804	1/4 X 1/2 UNC TRUSS HD SCR	6
3	144C0806	1/4 X 3/4 UNC TRUSS HD SCR	2
4	14780800	1/4 UNC HEX NYLOCK NUT	2
5	14870800	1/4 TYPE A PLAIN WASHER	2
6	15000007	RAMP HOLDER, FEMALE END	1
7	15001380	LABEL-ID	1
8	15060054	1/4 SLAB BASE NUT	6
9	70000035	BRACKET-STOP, RAMP	1
10	71352016	GLIDE STRIP	2
11	71352115	RAMP WELDMENT	1

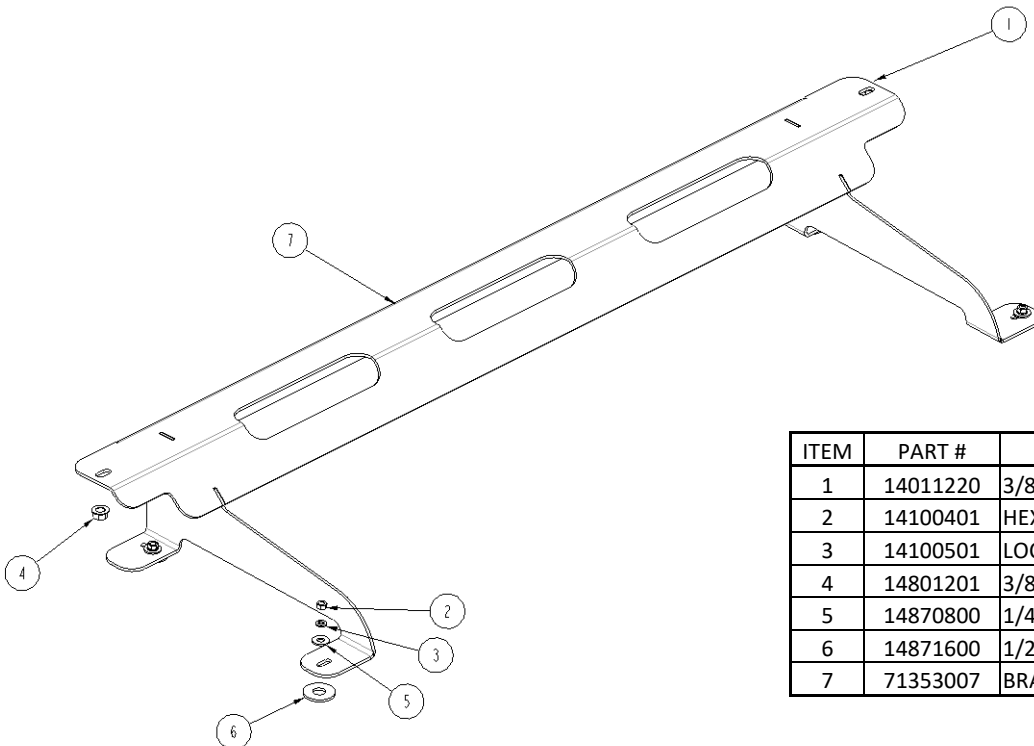

ITEM	PART #	DESCRIPTION	QTY
1	14011220	3/8 X 2 1/2 UNC HEX CAP SCR	2
2	14100401	HEX NUT M6 X 1	4
3	14100501	LOCK WASHER, MAGNI 501, M6	4
4	14801201	3/8 UNC TOP LOCK FL NUT	2
5	14870800	1/4 TYPE A PLAIN WASHER	4
6	14871600	1/2 TYPE A PLAIN WASHER	4
7	71353007	BRACKET - SUPPORT	1

SPECIFICATIONS for SS150 Single Deck for Chevrolet Suburban

DECK CAPACITY:

Maximum Load Length with Ramp Installed	92.5"
Maximum Load Length without Ramp Installed	96.0"
Maximum Load Width	47.5"
 VEHICLE REQUIREMENTS:		
Overall Deck Length (with Ramp up)	96.0"
Overall Deck Width	48.0"
 WEIGHT OF DECK (including ramp)		
	135 lbs.
 APPROXIMATE HEIGHT OF DECK FROM GROUND*		
	34 "
BIER PIN AVAILABLE	Yes
REAR WEAR PLATE	Yes
REMOVABLE RAMP	Yes
TIE DOWN METHOD	Existing Cargo Hold-Downs
INSTALLATION TIME	20 minutes
WARRANTY	1 Year

*Height may vary depending on vehicle.