

Untraceable: The Rising Specter of Ghost Guns

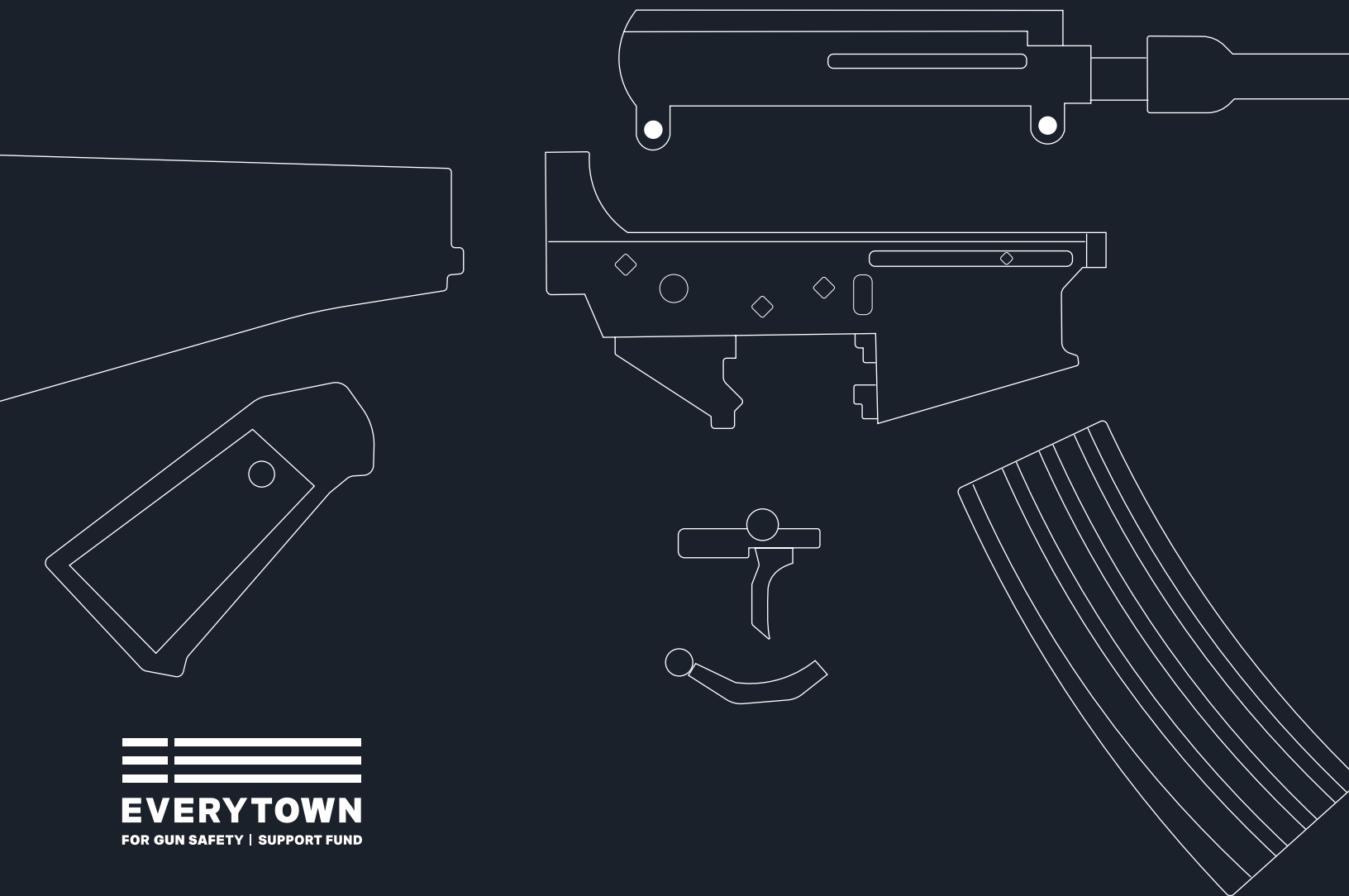
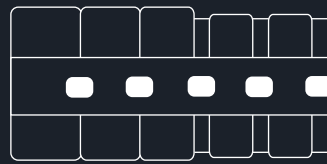

3

Introduction

5

Executive Summary

6

Ghost Gun Basics

10

Making Ghost Guns Is Easy and Cheap

12

Now There Are More Options Than Ever
to Get a Ghost Gun

16

Ghost Guns Are a Public Safety Threat

19

ATF Is Failing to Regulate Ghost Guns

21

Policy Solutions and Recommendations

24

Conclusion

25

Appendix A. Legal Overview
of State Ghost Gun Laws

Introduction

In California, a 16-year-old boy shot and killed two of his classmates and shot and wounded three others with a handgun.¹ In Washington D.C., ghost guns were used in four recent fatal shootings.² In Arizona, a neo-Nazi sex offender bragged on Facebook about his arsenal of firearms and homemade assault-style rifles.³ All of these people were legally prohibited from buying guns. But due to a dangerous wrong turn by ATF these individuals were able to access a haunting new source of firepower: ghost guns.

Ghost guns are the thread connecting a horrific series of recent shootings. These do-it-yourself (DIY) firearms are made from parts available without a background check and are predictably emerging as a weapon of choice for violent criminals, gun traffickers, dangerous extremists, and, generally, people legally prohibited from buying firearms. Because it has no serial number, a ghost gun cannot be traced back to where it came from, which frustrates police investigations and robs victims and survivors of justice.

The rise of ghost guns is the fastest-growing gun safety problem facing our country. But disturbingly little is known about who sells ghost guns, who buys them, and how much they are used in crime. The scant data available is disjointed and barely scratches the surface of the issue. To remedy this problem, Everytown for Gun Safety examined available data, including a sample of 80 online ghost gun part sellers and more than 100 federal prosecutions involving ghost guns, to find out who is selling and using these deadly weapons and what can be done about it.

Our analysis showed that across the country, law enforcement officers are recovering increasing numbers of homemade, unserialized guns from people who are legally prohibited from having guns. We found that today, it's easier and cheaper than ever for anyone to make their own guns. With a DIY kit ordered online and some commonly available tools, a novice can make their own pistol, like a Glock 19, or an assault-style rifle, like an AR-15 or AK-47, in just a few hours. The number of ghost gun sellers offering gun-making kits with all parts needed at discount prices is exploding, with some ghost gun kits retailing at nearly half the price of their finished-firearm counterparts.⁴

The prevalence of ghost guns and their potential to wreak havoc on every federal and state gun law are the predictable outcomes of the failure of the federal Bureau of Alcohol, Tobacco, Firearms and Explosives (ATF) to use its power to regulate “unfinished” frames and receivers, the building blocks of ghost guns. But it doesn't have to be this way. Although ATF does not currently classify “unfinished” frames and receivers as firearms, as it once did, it could address the ghost gun problem in one fell swoop by doing so again.

In the absence of ATF action addressing this threat, stakeholders across the country are searching for a solution. Some states are passing legislation to regulate ghost guns, while others are using existing laws to rein in the ghost gun market. Members of Congress have introduced bills to address ghost guns. And law enforcement agencies are beginning to track the use of ghost guns in crimes and sound the alarm on this trend.

Inaction is not an option. Unregulated sellers will continue to offer ghost gun building kits, traffickers will continue to make and sell completed, untraceable ghost guns, and more of these guns will end up in the hands of prohibited and often dangerous individuals—causing more deaths, injuries, and trauma in our communities.

Executive Summary

In response to the proliferation of ghost guns and the unique risks they pose to public safety, Everytown prepared this report to inform the public, lawmakers, and law enforcement about the dangers of ghost guns, and call on policymakers and corporations to act to stop ghost guns from falling into dangerous hands.

First, the report surveys the rising specter of ghost guns, finding that unregulated commercial sources are expanding and ghost guns are increasingly easy and inexpensive to make. An Everytown analysis found that 68 percent of online sellers in existence today began selling ghost gun parts after 2014. Sellers provide all the necessary parts for a functional ghost gun, and claim key ghost gun parts can be made in as fast as 15 minutes, often at rates below assembled firearms sold at retail.

It perhaps is not then surprising that law enforcement agencies are recovering homemade, unserialized firearms from criminals at alarming rates. While the absence of comprehensive reporting makes analysis difficult, Everytown examined more than 100 federal prosecutions involving ghost guns, finding that ghost guns are connected to violent criminal enterprises, gun trafficking rings, and far-right extremists. This sample included more than 2,500 ghost guns, many of which were assault-style or machine guns. This first-of-its-kind analysis shows that ghost guns are not only for hobbyists, as some have claimed, but rather they have become a critical part of the criminal market for firearms.

Next, this report examines ghost guns' status under the law. Federal law, in fact, provides the framework for regulating ghost guns, but the report explains why—based on a dangerous wrong turn by ATF—the building blocks for ghost guns are currently unregulated under federal law.

Last, the report lays out recommendations for actions that should be taken by corporations and at the local, state, and federal levels of government:

- ① **ATF should adopt a new definition of “firearm frames and receivers” that would reassert regulation over ghost guns—like the proposed new definition formally submitted to ATF by Everytown in December 2019.⁵**
- ② **If ATF fails to act, Congress should enact legislation to overrule ATF’s interpretation and clarify that “unfinished” frames and receivers are firearms, prohibit the manufacture, sale, transfer, purchase, and possession of a gun without a serial number, and require ATF to collect data and publicly report on the availability and recovery of ghost guns.**
- ③ **States should pass laws to prohibit the purchase and sale of ghost guns and the critical parts to manufacture them, mandate that firearms that are manufactured at home are serialized, and require the licensure of individuals who want to manufacture firearms.**
- ④ **In states with laws that already include frames and receivers in the definition of firearm, state attorneys general should issue legal opinions to clarify the law to ensure that law enforcement can treat these parts as firearms.**
- ⑤ **ATF and state and local law enforcement should collect data and publicly report on the availability and use of ghost guns.**
- ⑥ **Companies that facilitate sales (e.g., credit cards, internet service providers, shipping) of the building blocks of ghost guns should take proactive measures to prevent the spread of ghost guns.**

Ghost Gun Basics

A ghost gun is a DIY, homemade gun made from readily available, unregulated building blocks. It is produced by an individual rather than by an ATF-licensed manufacturer or importer.

A ghost gun has three key, related characteristics: It is unserialized, untraceable, and its building blocks are acquired without a background check. A firearm made by a licensed manufacturer or imported by an importer must be engraved with identifying information: a unique serial number, as well as the make and model. Under federal law as currently interpreted by ATF, ghost guns, because they require additional handiwork, are not required to have serial numbers and other identifying markings.

Because they are unserialized, ghost guns are untraceable. Typically, when police recover a firearm, they use the included serial number and other markings to initiate a trace request through ATF. ATF contacts the manufacturer to find out where it shipped the recovered gun, then the distributor to whom the gun was shipped, then the retailer who sold the gun to a consumer purchaser. By tracing a gun back to its first sale at retail, law enforcement agencies can have an initial lead in an investigation, identify straw purchasers and traffickers, and figure out how a gun arrived at a crime scene.

It is impossible to trace a ghost gun: It has no history, no records associated with it. As this report shows, the untraceability of ghost guns is one of their selling points and makes them attractive to criminals and gun traffickers trying to avoid being held responsible when their guns are recovered by law enforcement.

Because of ATF's current interpretation of the law, the core building blocks for a ghost gun can be acquired with no background check and no questions asked.

Understanding ghost guns requires knowing some basic facts about how guns are constructed. Frames and receivers are the core building blocks of firearms. In a pistol, the frame provides the basic bottom outline of the gun, housing the trigger and the magazine, while providing a foundation for the slide and barrel (i.e., the parts a bullet passes through when fired and cartridges are ejected from). In a semi-automatic rifle, the receiver houses the trigger parts and magazine and attaches to other parts.

Most ghost guns are made from "unfinished" frames and receivers. Unfinished frames and receivers are often marketed as "80%" complete, meaning a buyer needs to do only 20 percent of the work for the frame or receiver to be assembled into an operable firearm. As this report details, the difference between an unfinished frame or receiver and a finished, ready-to-use frame or receiver is a few tools and a couple of hours of work. But that small difference means everything: The unfinished frame or receiver has no serial number and can be sold without a background check, which enables people to circumvent state laws regulating assault weapons.

Parts of a Glock 17

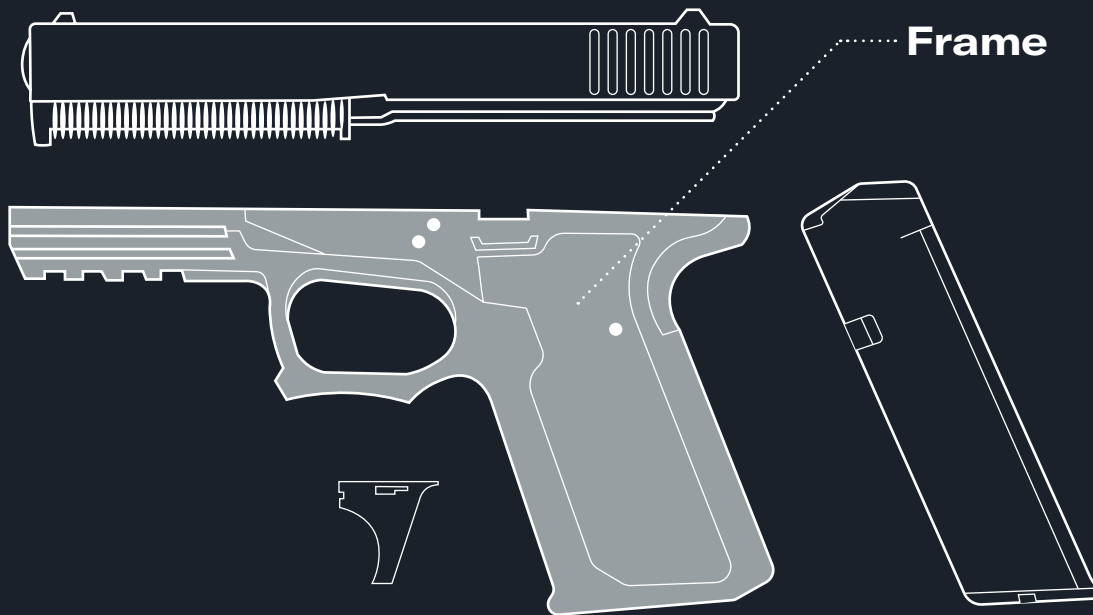

ATF says this is a firearm

ATF says this is not a firearm

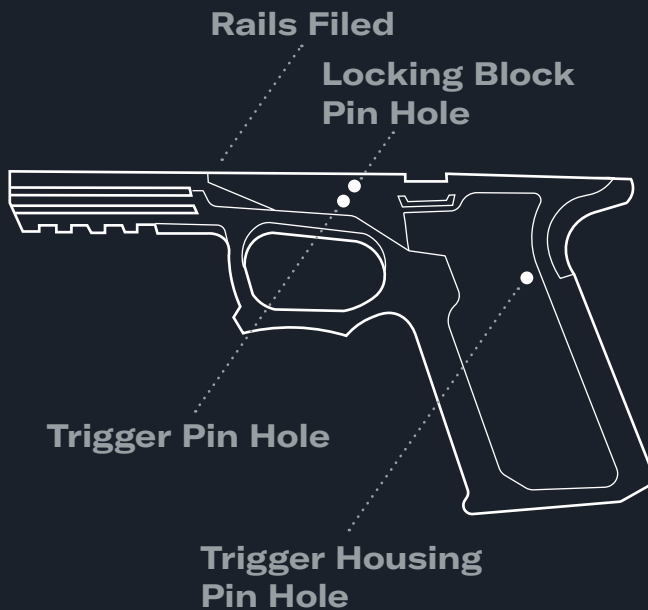

A person without gunsmithing skills can turn an unfinished frame into a functional frame with just **a few tools and less than an hour of work.**

Parts of an AR-15

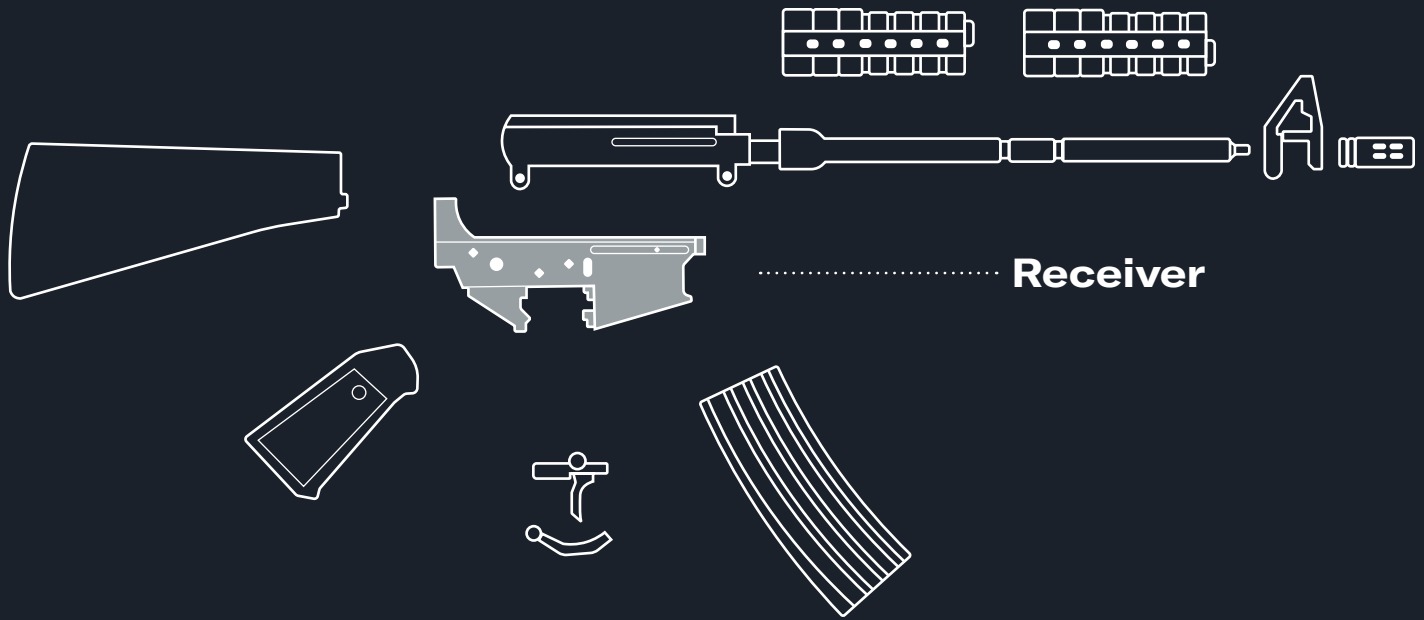

ATF says this is a firearm

ATF says this is not a firearm

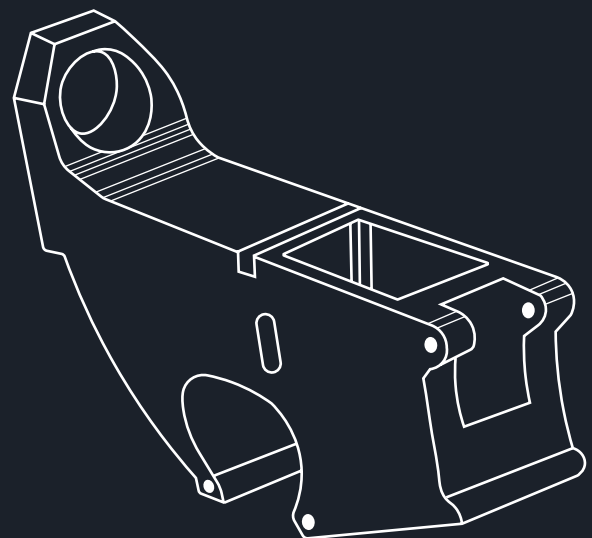
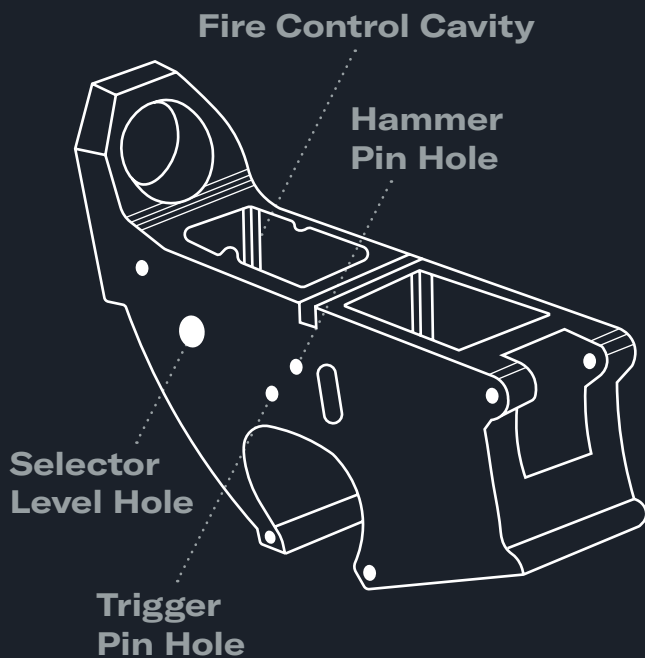

The difference between an unfinished receiver and a finished, ready-to-use receiver is **a few tools and a couple of hours of work.**

Is it a Ghost Gun?

This report focuses on the usual core building blocks of ghost guns—the unfinished frame or receiver. Downloadable guns, undetectable guns, and defaced guns are sometimes referred to as ghost guns, but that is not always true.

Downloadable Guns? Yes.

Downloadable guns are one type of ghost gun and are created with computer code instructions programmed into a 3D printer. 3D-printed guns do not have serial numbers, and the code and 3D printer can be acquired without a background check.

Undetectable Guns? Maybe.

Undetectable guns are firearms that cannot be detected by metal detectors or x-ray machines. Downloadable guns, because they typically are made with polymer, are undetectable with metal detectors unless a piece of metal is inserted into them. Federal law prohibits the manufacture, sale, and possession of undetectable guns.⁶

Defaced Guns? No.

Defaced guns are sometimes referred to as ghost guns, but defaced guns are different. A defaced gun is a commercially manufactured firearm that has had its serial number obliterated. A defaced gun gives a gun trafficker a similar advantage to a ghost gun: It is difficult to trace the gun back to them. Fortunately, ATF has the Obliterated Serial Number program to recover serial numbers from defaced guns,⁷ federal law bans defaced guns,⁸ and 30 states have enacted bans on defaced guns.⁹

Making Ghost Guns is Easy and Cheap

Decades ago, it may have required certain technical knowledge and skill to convert an unfinished frame or receiver into a fully functional firearm component—even more so for the unlicensed gunsmith who was building a receiver out of an aluminum block. But those days are over.

Everytown's analysis of the current market shows that ghost gun kits are designed and marketed for any person to do the necessary work. Online sellers have packaged the unfinished frame or receiver with all the other parts needed to complete the firearm and include instructional videos with easy-to-follow steps. These sellers are now one-stop shops for any person to get the building blocks, tools, and information to construct a fully operational ghost gun.

Online sellers¹⁰ of ghost gun parts advertise how easy it is to make a ghost gun. A seller of an AK-47 build kit announced that the kit was “one of the simplest processes to date.”¹¹ The seller helpfully provides a how-to video on the sale page.¹² Another seller boasts that, with their AR-15 kit, “building time doesn't take too long. Within an hour or two, you should be breaking it in at the range.”¹³ The top five instructional videos posted on YouTube that give guidance on finishing either a frame or receiver have been viewed over 3 million times.¹⁴

Sellers frequently offer a jig with their ghost gun kits. A jig is a device that fits around a frame or receiver and guides the drilling and milling necessary to finish the unfinished frame or receiver so that it is ready to be assembled into a functioning firearm. The kits also often include the exact drill bits necessary to finish the frame or receiver. All you need is an internet connection, a credit card, a file, and a drill—you can get everything else delivered straight to your home.

DOMINATE YOUR NEXT BUILD
AR-15 RIFLE BUILD KITS
SUITABLE FOR ALL SKILL LEVELS
SHOP AR15 BUILD KITS

This advertisement features a dark background with various AR-15 rifle components like the upper receiver, lower receiver, magazine, and trigger assembly. The text is in white and yellow, with the main title in large, bold letters.

★★★★★ 03/02/2020

Good kit!

The kit has everything you need to get setup and ready for an affordable price! Definitely recommended!

The review includes a photograph of the build kit components laid out on a white surface. The components include the upper and lower receivers, a magazine, a trigger assembly, and various small parts in clear plastic bags. Navigation arrows are visible at the bottom of the image.

One website offering rifle- and pistol-building kits announces that their jig “makes it ridiculously easy for a non-machinist to finish their 80% lower in under 1 hour with no drill press required.”¹⁵ Another seller offers a jig for a variety of rifle receiver types that can be used to complete an unfinished receiver “in under 15 minutes with excellent results,”¹⁶ and another claims that “[w]ithout the use of a press you can now build with ease and not spend a ton of money on the tooling needed.”¹⁷

Computer numerical controlled (CNC) machines make finishing a frame or receiver even easier. CNC machines do the drilling and milling for the user, guided by computer code. Insert an unfinished receiver, select the appropriate design file, and a short time later you will have a precisely made, finished receiver. The creator of one of these devices specially designed to work on firearms said the purpose of his product was to help people with no technical expertise complete a ghost gun quickly.¹⁸

Sellers of ghost gun kits and unfinished frames and receivers offer good prices. Everytown’s research found that it is possible to purchase an AR-15 build kit and a lower receiver for as little as \$345.¹⁹ And kits for making Glock-type pistol kits with a frame can go for as little as \$400.²⁰ These prices compare favorably to the cost of buying an assembled firearm at retail.

Criminals take advantage of and profit from how easy and inexpensive it is to make ghost guns. A five-time convicted felon from Easthampton, Massachusetts, ordered all the parts he needed to make AR-15 rifles off the internet. Using a milling machine in his basement and following an instructional video, the man made ghost guns and sold them across state lines in New Hampshire, and claimed he could make a \$300 profit on each.²¹ Another convicted felon and alleged gang member in Salem, Massachusetts, made a profit by ordering ghost gun kits online for \$400 to \$500, then selling the assembled ghost guns for three times that amount.²² This man called himself a “beast” because he was the best at making ghost gun pistols. Using tools you can get at a hardware store, he needed only 30 minutes to transform an unfinished pistol frame and parts kit into a functioning gun.²³

Unfinished semi-automatic handgun frame with the jig to guide the work

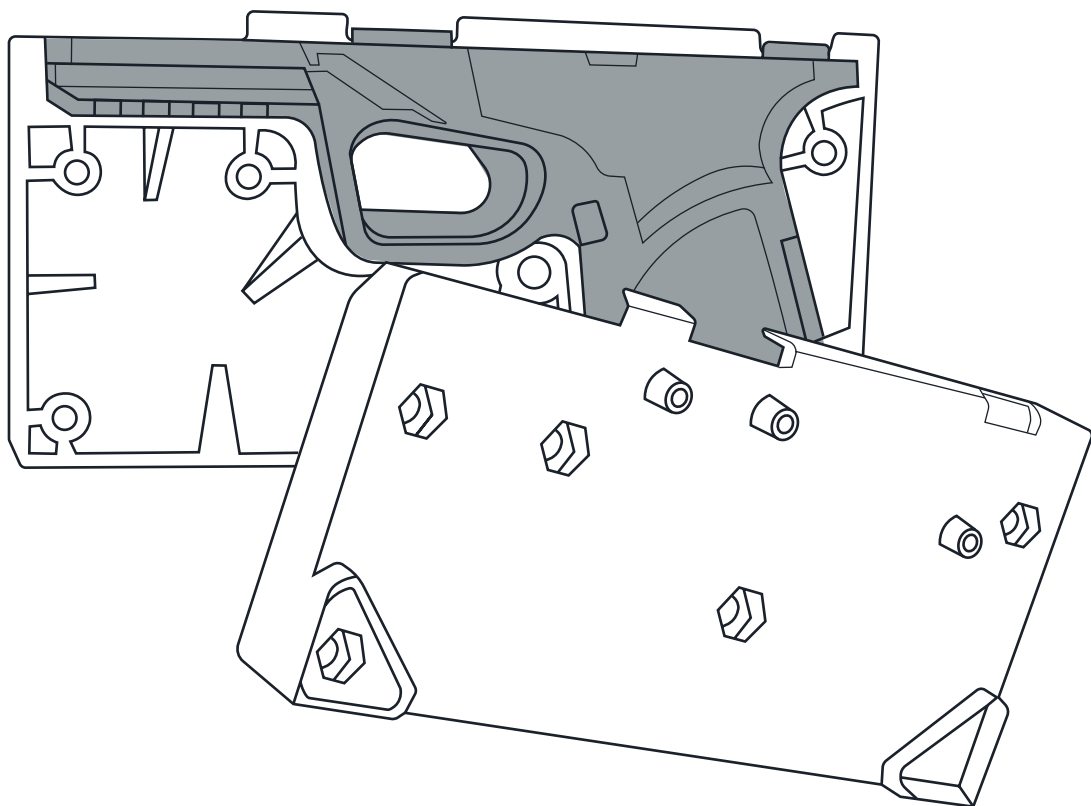

Now There are More Options than Ever to Get a Ghost Gun

The building blocks for ghost guns are available for purchase online, at gun shows, and at stores.²⁴ Major retailers like Brownells and MidwayUSA now offer unfinished frames and receivers and parts kits alongside regular firearms, accessories, and gear. The growth in the online market has been especially dramatic: Everytown's analysis uncovered 80 online sellers of unfinished frames and/or receivers.²⁵ These sites often offer all the parts a buyer needs to make their own firearm and there is frequently no limit on how many ghost gun building blocks a person can buy, with some sites even marketing unfinished frames and receivers in 5- and 10-packs.²⁶ Many of these websites include detailed guidance on how to finish machining a frame or receiver or even provide instructional videos that a novice builder can follow. A flourishing and unregulated online market in unfinished frames and receivers provides ready access to firearms to anyone who acquires a few basic tools and can follow simple instructions.

Sellers of ghost gun kits and unfinished frames and receivers clearly advertise that the products are meant to be built into operable ghost guns. The advertisements for unfinished frames and receivers feature pictures of completed firearms (not the unfinished product) that conspicuously show that there is no serial number. Lacking a serial number is a selling point for these products, with some products explicitly celebrating the lack of a serial number.²⁷ There is no doubt that these sellers are marketing firearms and no suggestion that the products being sold have any purpose other than becoming part of an operable weapon.

Complete Black AR15 Build Kit

Reference: MSRBK0-BLK-KIT

Condition: New product

Everything needed to go from nothing, to a complete black AR15, unserialized and unregistered. Bundled into a kit to save over \$100. Featuring a billet anodized lower, upgraded MFT butt stock with mil-spec kit, mil-spec lower parts kit with upgraded ergo grip, complete bcg, upgraded ambi-extended charging handle, a 16" QPQ barrel, and 15" MLOK hand guards with an A2 flash hider and BUS

\$997.99
- \$193.88 ~~\$1,191.87~~

VISA **MasterCard**

This product is no longer in stock

[Tweet](#) [Share](#) [Google+](#) [Pinterest](#)

Subscribe To When In Stock

SUBSCRIBE

[Print](#)

In addition, the sellers openly promote that these products are not regulated by ATF, often with copies of the formal letters sent from ATF saying the products are not regulated by ATF, alongside the pictures, parts, and instructional guides. Since these sellers are not required to get a license from ATF to sell the products, there is no reliable count of who is selling ghost gun building blocks as there is with gun dealers. Due to ATF's interpretation of the law, these businesses also operate outside any ATF regulation or oversight.

Everytown undertook an investigation to better understand the size of the online marketplace. An extensive search of the internet uncovered a sample of 80 sellers offering unfinished frames and/or receivers for ghost guns. Most offered shipment directly to the customer; major credit cards were accepted at nearly all of these sites.

Additional research uncovered that online ghost gun part sales and unfinished receivers have only recently become a widespread phenomenon. Of the 80 sellers identified, Everytown found that 68 percent began offering the building blocks for ghost guns for sale between January 2015 and May 2020—only 26 of the identified sellers were offering unfinished frames and/or receivers by the end of 2014.²⁸ An analysis of business registrations shows that these online retailers are based in states all across the country, with at least one seller operating in 26 states.²⁹



RAW 7075 FORGING 80% AR15 LOWER RECEIVER WITH ENGRAVING

\$55.00

★★★★☆ 2 Reviews

ENGRAVING

-- Select --

ENGRAVING POSITION

IN THIS COUNTRY, WE ARE A FREE PEOPLE!

However, many **state governments are stepping on our rights as free people to own firearms**. Our products give you back those rights, legally, and there is **Not a Damn thing** the government can do about it!

[LEARN MORE](#)

NO MORE GOVERNMENT OVERSIGHT ON YOUR RIGHTS

Building the lower receiver, yourself legally prevents the requirement of a government traceable serial number. **The lack of a serial number on your lower receiver prevents a tyrannical state government from knowing you even have it.** If they don't know you have it, they can't take it!

[BUY YOURS!](#)

Number of Sellers Offering the Building Blocks for Ghost Guns in 2014 Compared to Now

Operating in 2014

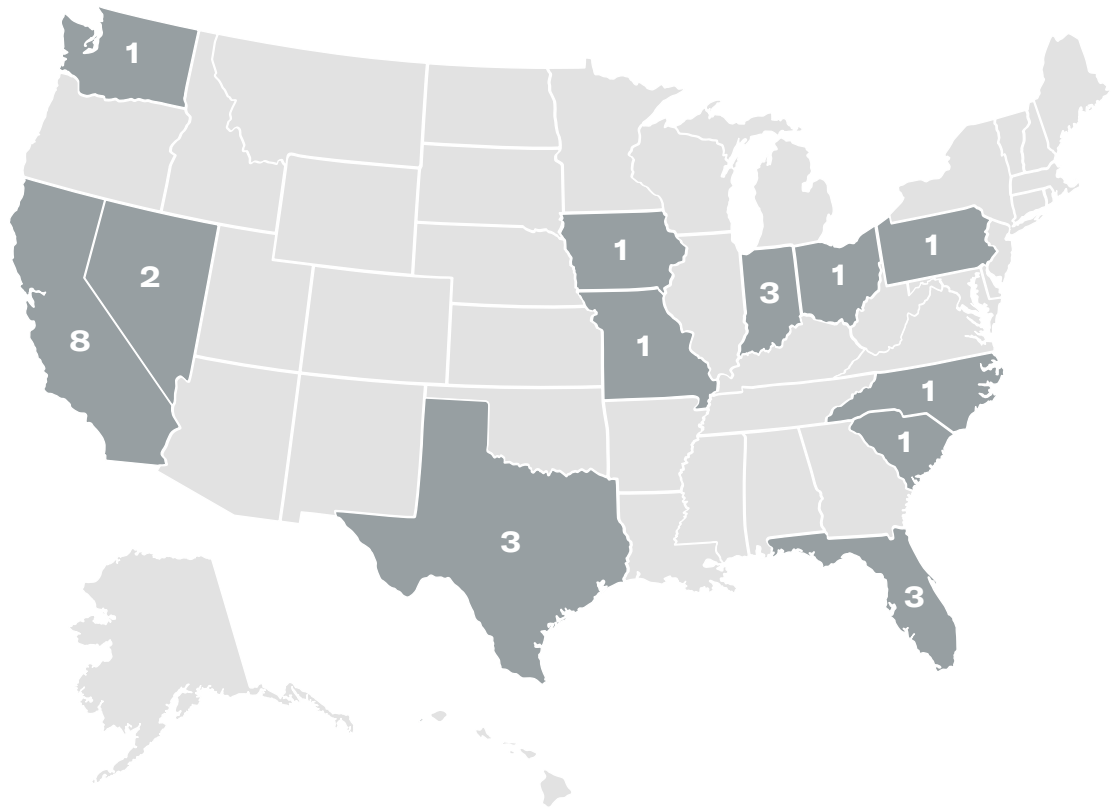

Operating Today

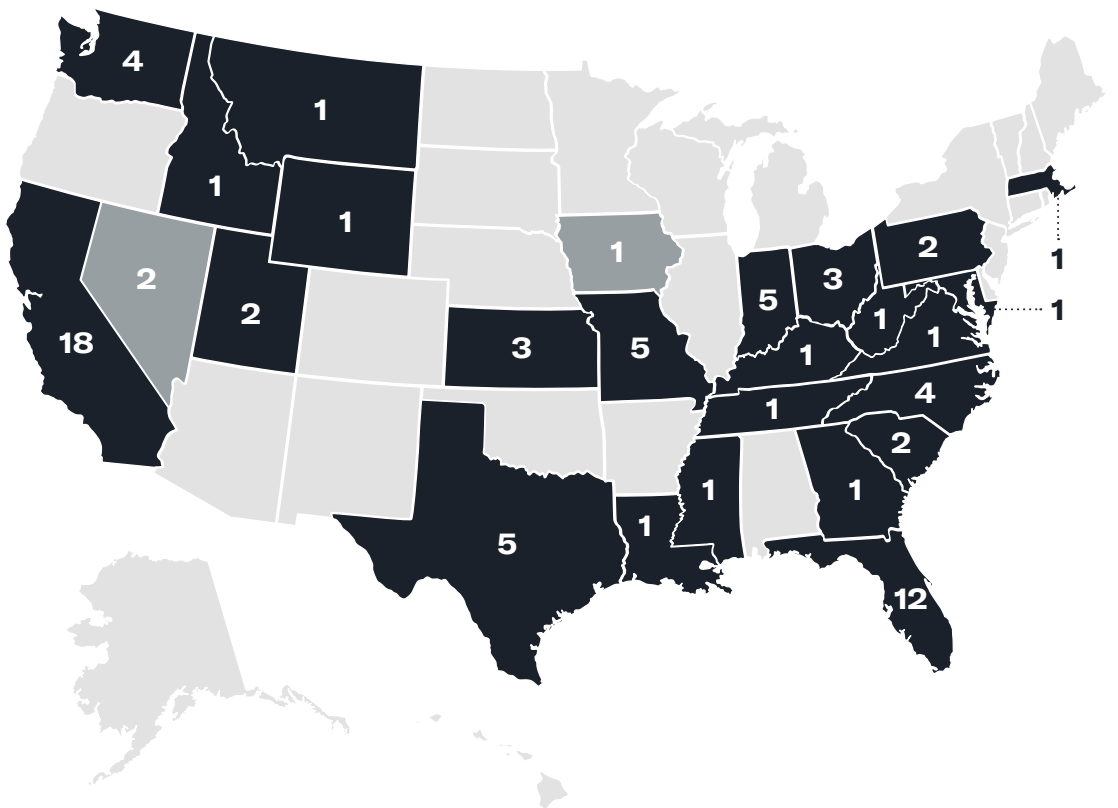

The emergence of this thriving market in ghost gun parts draws buyers who cannot legally purchase firearms. In Pennsylvania, an 18-year-old exchange student used one of these sites to get all the parts he needed to make a pistol. This was only discovered after he made a threat to “shoot up” his high school.³⁰ Several sellers attribute the popularity of ghost guns to perceived state action on gun safety, laying bare the appeal to those seeking to avoid gun safety laws.

Still others see these easy-to-access websites as the vehicle to turn ghost gun trafficking into a business opportunity. A professional welder applied his training to making AR-15 rifles during a period of unemployment.³¹ Another man quit his job because manufacturing firearms with a drill press in his home had become so lucrative.³² A Rhode Island ghost gun trafficker told ATF that he made homemade guns because he needed the money.³³

Online sellers are finding their inventories stretched thin as demand increases with recent political events and the COVID-19 pandemic:

We are backordered due to political events in Virginia & Pennsylvania. Our shop is working 24/7. Orders are shipping in 1 to 4 weeks.

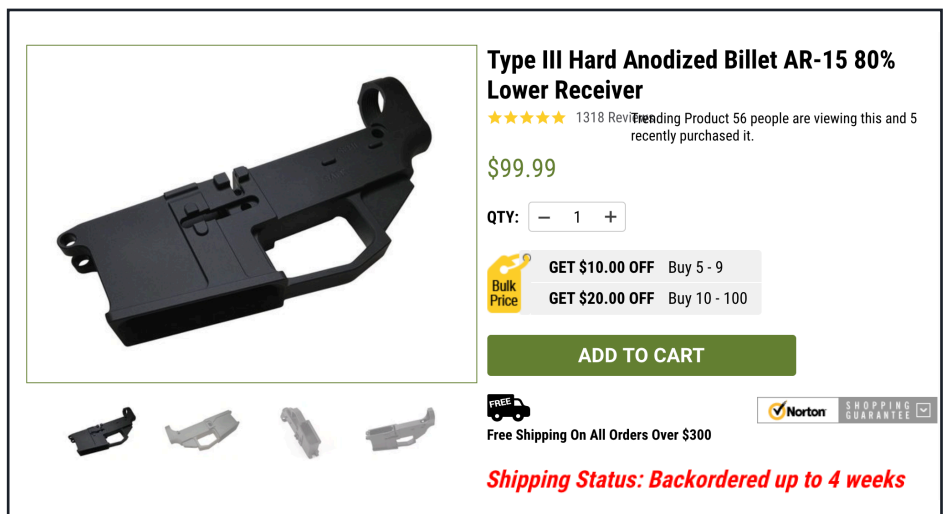

Type III Hard Anodized Billet AR-15 80% Lower Receiver
★★★★★ 1318 Reviews Leading Product 56 people are viewing this and 5 recently purchased it.

\$99.99

QTY:

Bulk Price GET \$10.00 OFF Buy 5 - 9
GET \$20.00 OFF Buy 10 - 100

ADD TO CART

FREE Shipping On All Orders Over \$300

Norton SHOPPING GUARANTEE

Shipping Status: Backordered up to 4 weeks



Polymer 80 Glock 19 PF940C 80% Compact Pistol Frame Kit
★★★★★ 150 Review(s) [Write a Review](#)

Add to Cart for Discount
Retail Price: \$149.99

[Questions about this item? Ask here.](#)

Availability: Out of Stock. **Free Shipping.**

Ghost Guns are a Public Safety Threat

Police, concerned about a software developer's paranoid behavior, committed the man for mental health treatment and seized his guns. Years later, even though he was barred from buying a gun legally, the man bought a gun-building kit and made a Glock-style pistol. One day, he penned a note vowing to fight "[f]or all those who have [been] isolated, alienated, marginalized, and rejected" and regretting that he would disappoint his family. Then he walked into work with his ghost gun pistol and shot and wounded four coworkers before police confronted and shot and killed him.³⁴

In communities across the country, law enforcement agencies are recovering increasing numbers of ghost guns. Thirty percent of guns recovered by ATF in California are unserialized, according to a 2019 report.³⁵ One official cited an even higher recovery rate at the local level: *"Forty-one percent, so almost half our cases we're coming across are these 'ghost guns,'"* said Carlos A. Canino, special agent in charge of the ATF Los Angeles Field Division. *"What's changed is technology. The technology makes it easy for someone to make one of these, even to mass produce these."*³⁶

Other communities have seen significant ghost gun recoveries, with sharp increases in the past year. Washington, DC, saw a 342 percent increase in ghost gun recoveries, with law enforcement recovering 115 ghost guns in 2019, compared to 26 in 2018.³⁷ In a single week in 2020, DC police recovered six ghost gun pistols and one ghost gun assault-style rifle.³⁸ Similarly, from Philadelphia to Syracuse to Denver, ghost gun recoveries are increasing in cities, and law enforcement is speaking out about this growing problem.³⁹

State and local law enforcement is recovering ghost guns from felons, domestic abusers, criminal gangs, drug dealers, extremists, and minors.⁴⁰ In the summer of 2018, a 25-year-old man was killed with a ghost gun in Washington, DC, during a shoot-out that left 32 shell casings at the scene.⁴¹ An assault-style ghost gun was used by a shooter to pin down two law enforcement officers during a shoot-out near Catholic University in Washington, DC.⁴²

A Syracuse man used a ghost gun to shoot his 6-year-old nephew in the back after he showed up at his sister's house acting erratically and said: "Do you trust me?" before firing at the little boy.⁴³ In 2019, Onondaga County, New York, police recovered 23 ghost guns. Only one ghost gun had ever been recovered before 2018.⁴⁴

Law enforcement leaders have been raising alarms over the effect ghost guns are having on public safety. Toniann Rebick, a criminalist with the San Diego Police Department, recalled being surprised when the first ghost gun that came across her desk, *"[t]hen a few weeks later, I had another one. All of a sudden these are common."*⁴⁵ *"We work so hard in ensuring that individuals pass background checks and are responsible gun owners,"* said Eddie Garcia, the chief of the San Jose Police Department. *"And that really gets thrown out the door when you have individuals that can just make a homemade gun."*⁴⁶ *"This is an emerging trend that is just continuing to increase,"* Bill McMullan, then-special agent in charge of the ATF's Los Angeles Field Division, said during a press conference in 2017. *"Criminals are making their own weapons because they're not able to buy them legally."*⁴⁷ In 2018, leading law enforcement associations, including the International Association of Chiefs of Police and the Major Cities Chiefs Association, identified this public safety threat and called for action to address it.⁴⁸

"We work so hard in ensuring that individuals pass background checks and are responsible gun owners.

And that really gets thrown out the door when you have individuals that can just make a homemade gun."

—Eddie Garcia, Chief of the San Jose Police Department.

These statistics and stories provide only a small window into this emerging crisis. Unfortunately, few law enforcement agencies have available data on ghost gun recoveries. Until agencies start tracking and reporting ghost gun recoveries, criminal prosecutions are the best indicator of the extent of the ghost gun problem.

Everytown reviewed 114 federal prosecutions from 2010 to April 2020 involving ghost guns, revealing 2,513 ghost guns connected to criminal activity.⁴⁹ This figure drastically under-represents the scale of ghost gun activity even within this set of prosecutions. For example, a defendant documented to have sold 23 homemade assault rifles to ATF informants and undercover officers boasted that he manufactured similar rifles "on a weekly basis" and had already trafficked 150 to customers in Mexico.⁵⁰ Another defendant sold six AR-15 style firearms to ATF agents and had "multiple boxes" of lower receivers with his drill press, vices, and other tools, indicating a much larger operation.⁵¹

Everytown's analysis revealed an unsurprising link between ghost guns and crime. In nearly half of the prosecutions reviewed, the defendants were prohibited from possessing any firearm and would not have passed a background check if one were required. More than 1,300 ghost guns connected to criminal activity were possessed, made, or sold by people prohibited from purchasing or possessing firearms, including felons, sex offenders, and domestic abusers. The vast majority, more than 2,200, of the ghost guns connected to criminal activity involved individuals charged with illegally manufacturing or dealing firearms. Nearly forty percent of these cases involved defendants who were prohibited from purchasing or possessing firearms.

The federal cases also show that ghost guns are frequently used by criminal organizations and drug traffickers to facilitate their crimes. More than 1,300 ghost guns were used or sold by criminal enterprises to facilitate crimes including gun trafficking, robbery, drug trafficking, terrorism, and murder.

In one case, an associate of the Vineland Boys street gang was charged with manufacturing ghost gun AR-15s by finishing lower receivers, and selling the completed ghost guns to gang members to use in crimes. One gang member used a ghost gun AR-15 that was built from parts purchased from an online seller in an attempted murder of a rival gang member.

Given the range of organized criminal groups represented in the sample, perhaps it is no surprise that high-powered assault weapons featured heavily: Nearly 75 percent of the prosecutions involved ghost gun assault-style rifles or parts for ghost gun assault-style weapons, while nearly half of the prosecutions involved ghost gun versions of firearm types strictly regulated under the National Firearms Act, like fully automatic firearms or short-barreled rifles.

While prosecutions involving ghost guns demonstrate that ghost guns are being trafficked by criminals and possessed by people prohibited from having firearms, these prosecutions undoubtedly represent only a slice of all ghost gun-related criminal activity. Because ghost guns are untraceable, law enforcement cannot trace a ghost gun used in a crime back to the dealer that sold it or the person who first bought it.

More than 2,500 ghost guns were connected to criminal activity in 114 federal cases from 2010 to April 2020.

Disarm Hate: Ghost Guns Arm Hate-Filled Extremists

Everytown's federal case review also found troubling examples of white supremacists obtaining ghost guns:

- In Arizona, FBI agents seized more than 20 guns from a neo-Nazi sex offender, including a ghost gun assault-style rifle.⁵² He was caught because he bragged about his arsenal on Facebook.⁵³
- A white supremacist group made its own fully automatic AR-15s after bombing a Minnesota mosque and attempting to bomb an Illinois women's health clinic.⁵⁴
- In January 2020, authorities arrested three members of a white supremacist terror group who planned to travel to Virginia where they hoped to use a gun rights rally in Richmond to ignite a civil war.⁵⁵ One member of the group had made an AR-15 using parts and a jig widely available online.⁵⁶ After test-firing the rifle at a shooting range and noticing that more than one bullet fired at a time, he remarked, "*Oh oops, it looks like I accidentally made a machine gun.*"⁵⁷

Searches of popular online forums show that extremists openly discuss the benefit of ghost guns and share advice on how to make them. On 4chan, an online platform popular with white supremacists, commenters shared tips for building ghost guns amid a steady stream of racist, anti-Semitic, and homophobic slurs. "*Only use a drill for the holes. Use a mill for the rails and finish up with a dremel with a small bit,*" one 4chan user advised. "*Don't listen to what these [slur] say, a drill press is fine for your holes.*" A rabidly racist and anti-Semitic user posted a guide for building an "untraceable, unserialized AR-15," which has been circulating on 4chan for years. After an extremist in Germany used a homemade gun to attack worshipers at a synagogue, 4chan users shared a guide for making the shooter's gun. Some commenters noted how cheap and easy it is to order gun kits online and enjoy home delivery with no background check. Others extolled the benefits of ghost guns' untraceability.

ATF is Failing to Regulate Ghost Guns

As described in this report, federal authorities are admirably scrambling to contain this outbreak of ghost guns used in serious crimes through investigations and prosecutions of criminals with fully assembled ghost guns. But federal law, if interpreted properly by ATF, could cut off this scourge at the source.

Federal gun laws regulate “firearms,” so the precise meaning of that term is important. Congress broadly defined “firearm” to include completed, fully operable weapons as well as their core building blocks, frames and receivers.

“The term ‘firearm’ means (A) any weapon (including a starter gun) which will or is designed to or may readily be converted to expel a projectile by the action of an explosive; (B) the frame or receiver of any such weapon; (C) any firearm muffler or firearm silencer; or (D) any destructive device. Such term does not include an antique firearm.”⁵⁸

ATF determines when a product qualifies as a firearm and is responsible for deciding, on a case-by-case basis, when a frame or receiver meets the definition of “firearm.” ATF makes these determinations when the sellers of “unfinished” frames and receivers want confirmation that their products will not be regulated by ATF. A business sends a sample frame or receiver to ATF, and ATF provides a determination letter explaining whether or not that frame or receiver qualifies as a firearm. The sellers often post these letters to reassure customers that the product is not regulated by ATF and does not require a background check.

In these letters, ATF has taken the position that an AR-15 lower receiver does not qualify as a firearm as long as one part of the receiver—the trigger cavity—is not milled out. ATF told businesses that these unfinished receivers could be sold without serial numbers and without background checks.⁵⁹ ATF made similar determinations about pistol frames.⁶⁰ It does not matter if the unfinished frame or receiver could be made into a functioning firearm in less than one hour. Therefore, businesses are free to sell these unfinished frames and receivers—and all the other parts of a firearm—to anyone who orders them online or buys them at a gun show or store, no matter how easy it is for the buyer to turn their purchase into a working gun. Even a convicted felon can purchase an unfinished receiver or frame online because, in ATF’s view, these are essentially unregulated pieces of metal—which also means many sellers are not subject to ATF regulation and oversight.

For several reasons, ATF’s current position—that unfinished frames and receivers are not firearms—is incorrect and unwise.

First, ATF’s current position is incorrect because it contradicts federal law. Under the definition of “firearm” currently in federal law, a frame or receiver qualifies as a firearm if it can, or is designed to, or may readily be converted to be part of an operable weapon. Therefore, any frame or receiver should be considered a firearm if—with a little time and some drilling and assembly work—it can be made into a functional gun.

Second, ATF’s current position is undercut by its past positions. From the 1980s until at least 2002, ATF classified a frame or receiver based on how much work remained for that item to be made part of a functioning firearm and how long that work would take. If it took only 75 minutes to drill out the interior of an AR-15 receiver for it to be used to construct a functioning rifle, ATF determined that the receiver was a firearm subject to federal law.⁶¹ But in the mid-2000s—after the federal Assault Weapons Ban expired and when homemade gun supplies and tools started to become more accessible online and more affordable—ATF started suggesting that it would not characterize an AR-15 receiver as a firearm as long as one part of the receiver—the trigger cavity—was not milled out.⁶² The reason ATF changed its position is unclear.

Third, ATF's position is unwise because it undermines all other federal gun laws. At their core, federal gun laws aim to "make it possible to keep firearms out of the hands of those not legally entitled to possess them."⁶³ Though written long before easily manufactured ghost guns became prevalent, these laws were designed to address the same problems that ghost guns now present: the uncontrolled interstate distribution of firearms, which allows dangerous individuals to readily acquire firearms without a background check.

Federal gun laws seek to control the distribution of firearms by regulating firearm businesses, requiring all firearms to have serial numbers, and requiring firearm businesses to sell firearms only to buyers who can legally possess them. These laws require any person or business that manufactures or sells firearms to be licensed to ensure that the legal market for firearms works to keep guns away from people who shouldn't have them.

All federal firearms licensees must make a record of all the guns they stock or make and all the guns they sell or export (i.e., their acquisitions and dispositions).⁶⁴ Manufacturers and importers must stamp each firearm with a unique serial number and other identifying markings and keep records of this information.⁶⁵ Since 1994, an individual purchaser must pass a background check before buying a firearm from a licensed dealer.⁶⁶

Federal gun laws cannot achieve their objectives if ATF simply allows businesses to sell DIY kits without performing background checks on purchase, without keeping any record of sales, and without placing a serial number on each frame and receiver.

The predictable result of ATF's current position is the scourge of ghost guns evidenced in local ghost gun recoveries and myriad federal prosecutions of violent criminals, gun traffickers, and extremist groups, an ironic if tragic case of the government inventing the very problem it seeks to solve.

Search The Store... Account Cart \$0.00

80% LOWERS 80% GLOCK 80% LOWER JIGS UPPERS BUILD KITS ENGRAVING PARTS & ACCESSORIES CONTACT

FEATURED CATEGORIES

80 PERCENT LOWERS SHOP NOW

80 LOWER JIGS SHOP NOW

80% GLOCK SHOP NOW

DOES [REDACTED] HAVE ATF DETERMINATION LETTER?

Yes, we have received a letter from the ATF certifying that they do not consider our 80% lowers a firearm. You can download a copy of this letter [here](#).

U.S. Department of Justice
Bureau of Alcohol, Tobacco, Firearms and Explosives

Martinsburg, WV 25405

www.atf.gov

903050:WJS
3311/300833

Santa Ana, CA 92707

Dear Mr. Smith,

This is in reference to your correspondence, with enclosed samples, to the Bureau of Alcohol, Tobacco, Firearms and Explosives (ATF), Firearms Technology Branch (FTB). In your letter, you asked for a classification of the partially completed AR-type receivers your company is planning to manufacture (see enclosed photos). Specifically, you want to know if the three submitted items, identified as samples 1, 2, and 3 (and reviewed below) would be classified as "firearms" under the Gun Control Act of 1968 (GCA).

SAMPLE #1

During the examination of this sample, FTB found that the following machining/drilling operations had been performed:

1. Front and rear assembly/pivot pin holes drilled.
2. Front and rear assembly/pivot-detent pin holes drilled.
3. Magazine-release and catch slots cut.
4. Rear of receiver drilled and threaded to accept buffer tube.
5. Buffer-retainer hole drilled.
6. Pistol-grip mounting area faced off and threaded.
7. Magazine well completed.
8. Trigger guard machined.
9. Receiver end-plate area machined.
10. Pistol-grip mounting area threaded.
11. Selector-lever detent hole drilled.

Policy Solutions and Recommendations

In February 2019, ATF received a tip about a ghost gun trafficker operating near Worcester, Massachusetts.⁶⁷ Talking to a customer who, unbeknownst to the trafficker, was an ATF informant, the trafficker said that he could make and customize any firearm the customer wanted, offering Glock-style pistols and fully automatic AR-15s for sale.⁶⁸ But the trafficker was worried after seeing media coverage about people “constantly getting busted with guns... without serial numbers.”⁶⁹ The trafficker suspected that ghost guns would be regulated eventually, but for the time being, “he was getting what he could before authorities started cracking down on it.”⁷⁰

As ghost gun recoveries rise and more crimes are committed with ghost guns, law enforcement organizations have sounded the alarm and state and local governments have begun taking action. Everytown recommends that corporations and policymakers at the federal, state, and local levels take the following actions to stop ghost guns from falling into dangerous hands and to prevent gun violence.

1— ATF should adopt a new definition of “firearm frame and receiver” to regulate the core building blocks for ghost guns.

Since the market for ghost guns has exploded, ATF has done nothing, as of May 2020, through formal rulemaking procedures to expressly address ghost guns.⁷¹ ATF is responsible for issuing regulations interpreting federal gun laws. In fact, a longstanding regulation defines the term “firearm frame or receiver” but that definition provides no clarity about the condition that a frame or receiver must be in to qualify as a firearm. The regulation was not meant to provide that clarity; ATF enacted it to specify the place where a manufacturer or importer should place a firearm’s serial number and other markings.⁷²

ATF could easily change its position that unfinished frames and receivers are not firearms if it amended this regulatory definition. An amended definition could make clear that a frame or receiver is a firearm if it is designed to be part a functioning firearm, or could easily be turned into one.

Former acting director of the ATF, Thomas Brandon, said he thought ATF should reclassify ghost gun kits as firearms and, prior to his retirement in April 2019, was ready to recommend that certain ghost gun kits be reclassified as firearms because of the ease of assembly.⁷³

In December 2019, Everytown submitted a formal request to ATF to issue a new regulation that would reassert federal regulation of unfinished frames and receivers and clarify that the lower receiver of an AR-15 is covered by the 1968 Gun Control Act’s definition of firearm. ATF should adopt a new definition of firearm frame or receiver to read like this:

Firearm frame or receiver. That part of a firearm which provides housing for the trigger group, including any such part (1) that is designed, intended, or marketed to be used in an assembled, operable firearm, or (2) that, without the expenditure of substantial time and effort, can be converted for use in an assembled, operable firearm.

ATF could commence rulemaking immediately and is under pressure to do so: in February 2020, US Senate Minority Leader Chuck Schumer of New York wrote to US Attorney General William Barr and ATF Acting Director Regina Lombardo calling on ATF to regulate unfinished frames and receivers.⁷⁴ In April 2020, Members of the House Judiciary Committee also sent a letter to the ATF seeking answers regarding the measures the ATF has undertaken to address the surge in ghost guns sales during the COVID-19 pandemic.⁷⁵

2— Congress should enact legislation to regulate ghost guns.

Should ATF fail to act, Congress can pass legislation to overrule ATF's interpretation and address the ghost gun problem. In the 116th Congress, bills have been introduced to regulate unfinished frames and receivers as firearms, prohibit the manufacture, sale, transfer, and purchase of a gun without a serial number, and require government reporting on the availability of ghost guns. For example:

- Representative David Cicilline (D-RI) sponsored the Untraceable Firearms Act of 2019, which would regulate unfinished frames and receivers as firearms and prohibit the manufacture, sale, transfer, and purchase of a gun without a serial number.⁷⁶
- Along similar lines, Representative Mike Quigley (D-IL) introduced the Trafficking Reduction And Criminal Enforcement (TRACE) Act, which would classify unfinished frames and receivers, and gun-building kits, as firearms.⁷⁷
- Representative Adriano Espaillat (D-NY) introduced the Ghost Guns Are Guns Act, which would treat as a firearm any combination of parts for making into a firearm.⁷⁸

In addition to passing the bills mentioned here, Congress should enact legislation to ensure that the definition of receiver covers the AR-15, require ATF to collect data and publicly report on the availability and recovery of ghost guns, and regulate the businesses that sell unfinished frames and receivers and gun-building kits.

3— States should enact laws to regulate ghost guns.

While a strong federal solution is critical to cutting off easy access to the parts and kits that make it so easy for criminals and other prohibited people to create unserialized and undetectable firearms, states can and should take action to empower local law enforcement to act to prevent the trafficking and criminal use of ghost guns.

In fact, several states have taken action to regulate ghost guns, and several more, including Delaware,⁷⁹ Hawaii,⁸⁰ New York,⁸¹ Maryland,⁸² and Rhode Island,⁸³ were actively considering ghost gun legislation before the COVID-19 pandemic led to the early adjournment or suspension of most state legislature's sessions. The District of Columbia, realizing the urgent need for action based on the rise of ghost guns used in crime, passed emergency legislation to stop the unregulated sale of the building blocks for ghost guns as the DC Council works on a permanent solution.⁸⁴

States have taken different approaches to regulating ghost guns, but at a minimum, these laws should make it illegal to purchase or sell ghost guns and the critical parts to manufacture them. This could include provisions to ensure that unfinished frames and receivers cannot be obtained without a background check and provisions to ensure that any firearms that are manufactured are serialized. States can also consider restrictions that require the licensure of individuals who want to manufacture firearms.⁸⁵ (See *Appendix A for an overview of state ghost gun laws.*)

4— State attorneys general should issue legal opinions to clarify existing laws to ensure that law enforcement can treat ghost gun parts as firearms.

Recognizing the threat to public safety posed by ghost guns, state attorneys general have also taken strong steps to regulate ghost guns.

In several states, state law already includes frames and receivers in the definition of firearms. As with federal law, these laws can and should be interpreted to classify unfinished frames and receivers as firearms. In many places, state attorneys general have the power to issue legal opinions to clarify the law, and an opportunity exists to ensure that law enforcement can treat these parts as firearms. That is exactly what the Pennsylvania Attorney General recently did when he issued a legal opinion to clarify that 80% receivers meet the definition of receivers under current Pennsylvania law.⁸⁶ The effect of this was to serve notice to law enforcement that these unfinished receivers should be treated like firearms for the purposes of enforcing certain Pennsylvania firearms laws.⁸⁷

Opportunities also exist to ensure that companies selling these products have taken steps to market and distribute them in compliance with state law. The New Jersey Attorney General sued a seller of AR-15 kits for advertising, offering, and selling the kits to New Jersey residents without warning that ghost guns are illegal under state law.⁸⁸ The New York Attorney General sent cease-and-desist letters to ghost gun companies who were offering ghost gun parts and kits for sale in possible violation of state firearm laws.⁸⁹

5— ATF and state and local law enforcement should collect data and publicly report on the availability and use of ghost guns.

On February 5, 2020, FBI Director Christopher Wray appeared before the Judiciary Committee of the US House of Representatives, where he was asked whether the FBI had seen an increase in the number of ghost guns during FBI investigations.⁹⁰ Director Wray, while acknowledging the growing concern at the FBI over ghost guns, was unable at the time of the hearing to provide statistical information about ghost guns. This brief exchange highlights the simple fact that to better respond to the threat of ghost guns, we need better data and information about them and their use in gun crime. After the hearing, Representative Madeleine Dean (D-PA) sent a letter to Director Wray following up on his comments and requesting data and information on ghost gun recoveries.⁹¹

While ATF and other law enforcement agencies have released some limited information about the number of ghost guns and their use in gun crime, it is critical that we have strong national data and a process in place to record the number of ghost guns used in gun crimes and to know how many are recovered by ATF. To accomplish this, ATF should immediately develop an internal data collection process to record when ghost guns are involved in a criminal investigation and should release data about their use in crimes to the public as part of its reporting on crime gun recoveries. This data should be used by policymakers, researchers, and law enforcement to develop more effective and targeted policy solutions to address ghost guns.

The National Defense Authorization Act for Fiscal Year 2020, which was signed into law on December 20, 2019, included a provision similar to legislation introduced by Representative Max Rose (D-NY)⁹² that directs the Department of Homeland Security to conduct an annual threat assessment of ghost guns for the next four years, with the first report due in June 2020.⁹³

6— Companies should not facilitate the sale of ghost guns in light of the risk that these firearms will be obtained by prohibited people or used in crimes.

The companies selling the building blocks for ghost guns are aware that their products are being used illegally, but they have not taken any steps to prevent firearms from falling into the wrong hands. Given that these manufacturers actively court business from those seeking to evade the law, it is unlikely that they will voluntarily change their business practices to guard against criminal abuse.

But the companies that facilitate the online acquisition of ghost guns can do the right thing by putting conditions on using or withholding their services. Mastercard, Visa, Discover, and American Express need not process sales of products like these that run a substantial risk of being used illegally. The internet service providers that host these websites can decline business from ghost gun operators, as GoDaddy and Google did with the The Daily Stormer website.⁹⁴ And common carriers like FedEx need not agree to ship packages that contain the building blocks of ghost guns. Absent meaningful action from government, these private actors could do a great deal to protect our communities from ghost guns.

Conclusion

Ghost guns are a threat to public safety. ATF's failure to regulate has allowed a marketplace for ghost guns to thrive that is being exploited by violent criminals, gun traffickers, and extremist groups. ATF can and should take immediate action to update the regulations and put a stop to the unregulated sale of the building blocks for ghost guns.

Appendix A. Legal Overview of State Ghost Gun Laws



California: Requires serial numbers and regulates the building blocks for ghost guns.

California requires all manufactured or assembled firearms to bear a unique serial number or mark of identification.⁹⁵ Prior to assembling a firearm, or upon moving into the state, people must apply to the California Department of Justice to obtain a unique serial number or mark of identification for unserialized guns.⁹⁶ The Justice Department conducts a background check and ensures compliance with state law before issuing the identification number.⁹⁷ Upon receiving the identification number, the owner must affix it to the firearm.⁹⁸ California prohibits the sale or transfer of these firearms.⁹⁹

In 2019, California expanded its law to require that by July 1, 2024, all sales of firearm precursor parts must take place through a licensed vendor and to require that the state conduct background checks on transfers of frames and receivers by July 1, 2025.¹⁰⁰ Online sellers of precursor parts will have to deliver their parts to a vendor before they can be transferred to a buyer.¹⁰¹



Connecticut: Requires serial numbers, regulates the building blocks for ghost guns, and regulates undetectable firearms.

Connecticut prohibits manufacturing firearms without obtaining a serial number from the Connecticut Department of Emergency Services and Public Protection, which is issued after a background check, and affixing it to the firearm.¹⁰²

Connecticut also requires a background check before the sale and transfer of unfinished frames and lower receivers, generally prohibits the sale or transfer of unfinished frames and lower receivers without serial numbers and prohibits people prohibited by state law from having guns from possessing these parts.¹⁰³ Finally, Connecticut prohibits guns made from polymer plastic that are undetectable by metal detectors.¹⁰⁴



Massachusetts: Regulates undetectable firearms.

Massachusetts prohibits the sale, transfer, or possession of any weapon that is undetectable by a walk-through metal detector or x-ray machine commonly used at airports.¹⁰⁵



New Jersey: Requires a license to manufacture a firearm; regulates undetectable firearms; and prohibits distribution of downloadable gun schematics.

New Jersey prohibits manufacturing firearms without a manufacturer's license¹⁰⁶ and generally prohibits the purchase of frames and receivers without a serial number.¹⁰⁷ New Jersey also prohibits the manufacture or sale of undetectable firearms¹⁰⁸ and generally prohibits using a 3D printer to manufacture firearms and the distribution of instructions for the 3D printing of firearms.¹⁰⁹



New York: Regulates undetectable firearms.

New York prohibits the possession, transport, and manufacture of an undetectable firearm.¹¹⁰ The legislature is considering legislation regarding untraceable firearms.



Virginia: Regulates undetectable firearms.

Virginia prohibits the sale, transfer, and possession of plastic firearms, which are defined as any firearm containing less than 3.7 ounces of electromagnetically detectable metal in the barrel, cylinder, slide, frame, or receiver and which, when subject to an x-ray machine commonly used at airports, does not generate an image that accurately depicts its shape.¹¹¹



Washington: Regulates undetectable and untraceable firearms.

Washington prohibits facilitating the manufacturing of undetectable or untraceable firearms by a person prohibited from having guns,¹¹² prohibits the manufacturing or possession of undetectable firearms,¹¹³ and prohibits the manufacturing of an untraceable firearm with the intent to sell it.¹¹⁴

- Alain Stephens, "Officials Confirm Santa Clarita Shooter Used a Ghost Gun," *The Trace*, December 9, 2019, <https://bit.ly/2T80XJl>.
- Peter Hermann, "D.C. mayor signs law banning 'ghost gun' kits from District," *Washington Post*, March 11, 2020, <https://wapo.st/3eq7s1L>.
- Meg O'Connor, "How Facebook Led the FBI to Seize Guns from an Arizona 'Neo-Nazi,'" *Phoenix New Times*, May 16, 2019, <https://bit.ly/2T8LMj9>.
- This comparison was calculated using the price of one of the cheapest ghost gun build kits identified on the internet for an AR-15 (\$365) and the price of a completed, entry-level AR-15 sold by Cabela's, Cabela's, an outdoor equipment store (\$650). "Rifle Classic Kit 80%," [On File], accessed March 3, 2020; "Smith & Wesson® M&P 15 Sport II Semiautomatic Tactical," Cabela's, accessed March 20, 2020, <https://bit.ly/2wh7d9g>.
- Everytown for Gun Safety, "Everytown for Gun Safety Urges ATF to Correct Regulatory Failure Allowing Untraceable 'Ghost Guns' into Communities across the Country," press release, December 12, 2019, <https://everytown/2laYGqp>.
- 18 U.S.C. § 922(p).
- Bureau of Alcohol, Tobacco, Firearms, and Explosives, "Fact Sheet - National Tracing Center," accessed March 3, 2020, <https://bit.ly/2x7qKZL>.
- 8 U.S.C. § 922(k).
- AK, AR, AZ, CO, CT, DE, FL, GA, HI, IL, KS, KY, LA, MA, MD, ME, MN, MO, MT, NC, NE, NJ, NV, NY, OH, OK, RI, SC, SD, and VA.
- In the interest of not publicizing the sellers of ghost gun building blocks, this report does not include the names of sellers or their websites. Screenshots of all products and descriptions cited are on file.
- "AKM AK47 80% Complete Build Kit," [On File], accessed March 6, 2020.
- "AKM AK47 80% Complete Build Kit," [On File].
- Gary Vela, "Why Is Purchasing an AR-15 Kit Is Great for Beginners?," [On File], May 10, 2019.
- The top five videos on YouTube were identified by searching for "80 percent receiver" and "80 percent frame" and sorting instructional videos by view count.
- "Best 80% Receivers, Jigs, Parts & More," [On File], accessed February 29, 2020.
- "The Router Jig Pro Multiplatform - AR-15/AR-9/AR-45/308/AR-10," [On File], accessed February 29, 2020.
- "AKM AK47 80% Complete Build Kit," [On File].
- Ghost Gunner "3D Gun Printer": Cody Wilson and James Reeves Interview*, YouTube, 2018.
- "Rifle Classic Kit 80%," [On File].
- "G19 Kit 80% - Compact - Unfinished," [On File], accessed March 3, 2020.
- Complaint, *US v. Blackmer*, 16-CR-00009, at 6-9 (D.N.H. Nov. 9, 2015).
- Complaint, *US v. Echeverria, et al.*, 19-MJ-06527, 11-12 (D. Mass. Oct. 28, 2019).
- Complaint, *US v. Echeverria, et al.*, 19-MJ-06527, 12, 16 (D. Mass. Oct. 28, 2019).
- Everytown collected data on online sellers who currently offer building blocks for ghost guns for sale particularly 80% receivers and frames. These sellers were identified using search engines, forums, and websites listing the best 80% lower receivers, frames, and jigs on the market. While this list of companies was not designed to be exhaustive, Everytown's sample aimed to capture prominent sellers in the online marketplace. There is no official list of manufacturers or sellers of ghost gun parts.
- Everytown used a combination of business records and archive.org, a website that allows you to see the history of over 418 billion web pages, to determine the approximate year sellers first started selling 80% frames and/or receivers, and marked that year as when the seller entered the ghost gun business. Sellers may have started offering ghost gun parts prior to the year we identified.
- "80% Lowers Fire/Safe Marked (10-Pack)," [On File], accessed March 6, 2020.
- "Rifle Classic Kit 80%," [On File].
- Everytown was able to determine the approximate start year for all 80 sellers. Of the 80 sellers for which Everytown was able to determine the approximate year in which the seller began marketing 80% frames and/or receivers, 54 of them started between January 2015 and May 2020.
- Everytown used a combination of seller websites, state business registration databases and archive.org to determine the state where the seller is based.
- US Department of Justice, US Attorney's Office for the Eastern District of Pennsylvania, "Taiwanese Exchange Student Who Threatened to Shoot Up School Sentenced on Federal Ammunition Charge," press release, November 19, 2019, <https://bit.ly/2Tvig62>.
- Government's Sentencing Position for Defendant Steven Carrillo, *US v. Manzo*, 16-CR-00749, at 4-8 (C.D. Cal. May 26, 2017).
- Complaint, *US v. Smith*, 18-CR-00043, at 14, 17-18 (E.D. Cal. Feb. 16, 2018).
- Criminal Complaint, *US v. Ladwig*, No. 18-MJ-00448, at 6 (D.R.I. Dec. 12, 2018).
- Chris Aadland, "WTS Paradigm Gunman Exploited Loopholes to Buy Parts for Gun Used in Shooting, DA Says," *Wisconsin State Journal*, January 8, 2019, <https://bit.ly/32Ba5cC>. [Police Report on File].
- Alain Stephens, "Ghost Guns Are Everywhere in California," *The Trace*, May 17, 2019, <https://bit.ly/2T5YAGW>.
- Brandi Hitt, "'Ghost Guns' Investigation: Law Enforcement Seeing Unserialized Firearms on Daily Basis in SoCal," *ABC7 Los Angeles*, January 30, 2020, <https://abc7.com/5893043/>.
- Amanda Michelle Gomez, "DC Recovered 115 Ghost Guns in 2019, Up From 25 the Year Before," *Washington City Paper*, January 10, 2020, <https://bit.ly/3aktwt3>.
- Metropolitan Police Department (Washington, DC), "MPD's Weekly Firearm Recoveries: January 27, 2019 to February 3, 2020," press release, February 4, 2020, <https://bit.ly/39aDcGl>.

39. In Philadelphia, ATF recovered 42 ghost guns between June 2018 and June 2019. Jesse Hughes, "Ghost Guns Create a Haunting Problem for Pennsylvania," *Fox 43*, December 16, 2019, <https://bit.ly/2PyuOs8>; ATF agents at the Denver Field Division recovered 23 ghost guns in 2018. Jaclyn Allen, "Untraceable, Unregulated and Easy to Build: Colorado and the Increasing Popularity of 'Ghost Guns,'" *ABC Denver 7*, February 22, 2019, <https://bit.ly/2TrSiAA>; In New York State, the Onondaga County District Attorney warned that the county "has seen a significant increase in the possession and use of 'ghost guns,' with over 2 dozen confiscated or secured by our local police agencies and the state police in the last year." Douglass Dowty, "DA: Syracuse Man Shot 6-Year-Old Nephew with Untraceable 'Ghost Gun,'" *Syracuse.Com*, January 6, 2020, <https://bit.ly/2wdXnV8>.
40. Melissa Pamer, "Father-Daughter Pair Charged After Assault Rifles, 66,000 Rounds of Ammunition Found in Temple City Gun Cache," *KTLA 5*, February 21, 2018, <https://bit.ly/39bh1iZ>; Bob Bennett, "Police: Convicted Felon Revealed Gun during Argument," *Press-Republican*, April 16, 2018, <https://bit.ly/2uFTUya>; Kelsey Hammon, "More Arrested Monday in Alleged Connection with Drug-Trafficking Operation," *Longmont Times-Call*, July 10, 2019, <https://bit.ly/39c82hM>; Sontaya Rose, "Fresno Police Gang Crackdown Busts Prostitution Ring, Dozens Arrested," *ABC30 Action News*, September 8, 2017, <https://abc30.com/2393264/>; Erin Vogt, "'Armed & Dangerous' Duo Found with Coke, Meth and Kids—Cops," *New Jersey 101.5*, August 6, 2019, <https://bit.ly/32BQxg0>; "Suspected Cocaine Dealer Arrested with a 'Ghost Gun,'" *Santa Barbara Independent*, May 17, 2019, <https://bit.ly/39fQwco>; Metropolitan Police Department (Washington, DC), "MPD's Weekly Firearm Recoveries: January 20, 2019 to January 27, 2020," press release, January 29, 2020, <https://bit.ly/2T9VuSj>; O'Connor, "Facebook Led the FBI to Seize Guns"; Stephens, "Ghost Guns Are Everywhere in California."
41. Peter Hermann and Tom Jackman, "District Seeks to Ban 'Ghost Gun' Kits as Seizures of Homemade Weapons Soar," *Washington Post*, February 27, 2020, <https://wapo.st/2TpZk91>.
42. Hermann and Jackman, "District Seeks to Ban 'Ghost Gun' Kits."
43. Dowty, "Syracuse Man Shot 6-Year-Old"; Douglass Dowty, "'Mommy!' Boy, 6, Moans after Uncle Shoots Him in the Back; Police Cleared in Killing Uncle," *Syracuse.Com*, December 19, 2019, <https://bit.ly/2VCZ8WD>.
44. Andrew Donovan, "An Alarming 23 Do-It-Yourself 'Ghost Guns' Were Ordered Online, Seized in Syracuse Last Year," *WSYR*, February 10, 2020, <https://bit.ly/2lcBAQL>.
45. Stephens, "Ghost Guns Are Everywhere in California."
46. Stephens, "Ghost Guns are Everywhere in California."
47. Dennis Romero, "Officials across the Country Fear a New Era of Untraceable Firearms," *NBC News*, August 1, 2018, <https://nbcnews.to/2VziWdy>.
48. National Law Enforcement Partnership to Prevent Gun Violence, "Statement on Proliferation of Untraceable Firearms," press release, September 4, 2018, <https://bit.ly/3ajYiSP>; International Association of Chiefs of Police, "To Address the Threat Posed by Untraceable Firearms Made Through 3D Printing and Unfinished Frames and Receivers," Resolution FC.08.t2018, November 1, 2018, <https://bit.ly/2TbebFq>.
49. Everytown identified prosecutions involving ghost guns or unfinished frames or receivers from press releases from US Attorneys' Offices, media reports, and court documents. Everytown reviewed court filings to determine details about each prosecution.
50. Complaint, *US v. Rodriguez, et al.*, 18-CR-00322 (S.D. Tex. Apr. 11, 2018).
51. Complaint, *US v. Candelario*, 16-CR-01643 (D. Md. June 22, 2016).
52. Bill of Particulars, *US v. Wells*, 17-CR-01114, (D. Ariz. Jul. 9, 2018); O'Connor, "Facebook Led the FBI to Seize Guns."
53. Complaint, *US v. Wells*, 17-CR-01114, (D. Ariz. Jul. 19, 2017).
54. Complaint, *US v. Hari, et al.*, 18-CR-20014, at 9, 12-13 (C.D. Ill. Mar. 13, 2018); Superseding Indictment, *US v. Hari, et al.*, 18-CR-20014, at 5-6 (C.D. Ill. May 2, 2018).
55. Pete Williams and Erik Ortiz, "Days before Virginia Gun Rally, FBI Arrests 3 Alleged White Supremacists," *NBC News*, January 16, 2020, <https://nbcnews.to/3ct0QpY>.
56. Motion for Detention Pending Trial, *US v. Lemley, et al.*, 20-MJ-00192, 20-MJ-00193, 20-MJ-00194, at *17-18 (D. Md. Jan. 21, 2020).
57. Complaint, *US v. Lemley*, 20-MJ-00192, at 5 (D. Md. Jan. 15, 2020).
58. 18 U.S.C. § 921(a)(3).
59. Letter from John R. Spencer, Chief, Firearms Technology Branch, ATF to Chris Coad, Ultra-Tech, Inc. (May 20, 2009); Letter from John R. Spencer, Chief, Firearms Technology Branch, ATF to Rick W. Miller, G&S Precision Machine (July 24, 2009); Letter from Earl Griffith, Chief, Firearms Technology Branch, ATF to Bradley Reece, Palmetto State Defense, LLC (Nov. 22, 2013).
60. Letter from John R. Spencer, Chief, Firearms Technology Branch, ATF to Alan Aronstein, Hi-Standard Manufacturing Company (Sept. 23, 2012).
61. Letter from Edward M. Owen, Jr., Chief, Firearms Technology Branch, ATF to Henry A. Roehrich, SGW Incorporated (May 3, 1983); Letter from Edward M. Owen, Jr., Chief, Firearms Technology Branch, ATF to Robert Bower, Jr., Philadelphia Ordnance, Inc. (May 25, 1992); Letter from Curtis H.A. Bartlett, Chief, Firearms Technology Branch, ATF to Lane Browne, Mega Machine Shop, Inc. (Dec. 27, 2002).
62. Letter from Sterling Nixon, Chief, Firearms Technology Branch, ATF to Justin Halford (Apr. 24, 2006) (underlining in original).
63. S. Rep. No. 90-1501, at 22 (1968).
64. 18 U.S.C. § 923(g).
65. 18 U.S.C. § 923(i).
66. 18 U.S.C. § 922(s), (t).
67. Affidavit of Special Agent, *US v. Bishoff*, 19-MJ-04496, at 6 (Sept. 23, 2019).
68. Affidavit of Special Agent, *US v. Bishoff*, at 8.
69. Affidavit of Special Agent, *US v. Bishoff*, at 12.
70. Affidavit of Special Agent, *US v. Bishoff*, at 12.
71. Federal laws do provide some checks on ghost gun trafficking, but they are reactive and inadequate to stem the problem. It is illegal to make a ghost gun intending to sell it (US Department of Justice, Bureau of Alcohol, Tobacco, Firearms and Explosives, "ATF Federal Firearms Regulations Reference Guide, 2014," September 2014, <https://bit.ly/39yhWum>). The same people who are prohibited from possessing a regular firearm are prohibited from possessing assembled ghost guns (18 U.S.C. § 922[g]). No one can legally sell a ghost gun to someone they know cannot legally buy it (18 U.S.C. § 922[d]). But these laws are too often too little, too late.
72. Hearings In re: Determining the Suitability of Proposed Regulations to Implement Recently Enacted Legislation Concerned with Federal Regulation of Commerce in Firearms, Department of the Treasury, Internal Revenue Service, Statement by Robert C. Zimmer, Sporting Arms and Ammunition Manufacturer's Institute, at 23 (Nov. 21, 1968); id., Statement of Charles Steen, Sarco, Inc., at 133.
73. Bill Whitaker, "Ghost Guns: The Build-It-Yourself Firearms that Skirt Most Federal Gun Laws and Are Virtually Untraceable," *60 Minutes*, May 10, 2020, <https://cbsn.ws/2YNSXR8>.
74. Charles E. Schumer United States Senator for New York, "Schumer Reveals: Onondaga Law Enforcement Is Seeing Frightening Rise of 'Ghost Guns' Used in Crimes; Senator Calls on Feds to Use Law Already on Books to Close the Loophole That Triggers Unregistered Ghost Guns & Work with Locals to Map Extent of Ghost Gun Parts in CNY," press release, February 10, 2020, <https://bit.ly/2uG5MjI>.
75. Letter from Jerrold Nadler United States Representative for New York District 10 and Members of the United States House of Representatives Committee on the Judiciary to ATF Acting Director Regina Lomardo, April 23, 2020, <https://bit.ly/3czj1mQ>.
76. H.R. 3553, 116th Cong. (2019).
77. H.R. 4255, 116th Cong. (2019).
78. H.R. 1266, 116th Cong. (2019).
79. Del. H.B. 277 (2020).
80. Haw. H.B. 2774 (2020).
81. New York State Senator Brad Hoylman, "Senators Hoylman and Kaplan, Assembly Members Rosenthal and Lavine Introduce Comprehensive Legislation Package to Eliminate Dangerous Ghost Guns," press release, February 14, 2020, <https://bit.ly/2VdmQ57>.
82. Md. H.B. 910 (2020).
83. R.I. S.B. 2004 (2020).
84. This emergency law lasts 90-days. Peter Hermann, "DC Mayor Signs Law Banning 'Ghost Gun' Kits from District," *Washington Post*, March 11, 2020, <https://wapo.st/2U58ec6>.

85. States should also carefully consider regulating undetectable guns, such as those printed with a 3D printer. This could include a prohibition on the manufacturing of 3D-printed firearms, a prohibition on posting 3D-printed gun plans online, or a general prohibition on possessing undetectable firearms.
86. Letter from Josh Shapiro, Attorney General, Commonwealth of Pennsylvania, to Colonel Robert Evanchick, Commissioner, Pennsylvania State Police, December 16, 2019, <https://bit.ly/2VzrHUI>.
87. After sellers of unfinished frames and receivers sued to challenge the policy, a Pennsylvania court temporarily prevented the Pennsylvania State Police from enforcing this policy towards unfinished frames and receivers but indicated that it would revisit its decision if the state police clarified aspects of the policy. Memorandum Opinion, *Landmark Firearms LLC, et al. v. Evanchick*, No. 694 M.D. 2019 (Pa. Commw. Ct. Jan. 31, 2020).
88. State of New Jersey, Department of Law & Public Safety, Office of the Attorney General, "AG Grewal Files First State Lawsuit Against 'Ghost Gun' Company for Offering Untraceable Guns in NJ," press release, March 22, 2019, <https://bit.ly/32BMecV>.
89. NY Attorney General Letitia James, "AG James Pumps Brakes On Online 'Ghost Gun' Sellers, Orders Cease And Desist Of Sales Into New York," press release, September 23, 2019, <https://on.ny.gov/2TGHcrj>.
90. United States Congress House Judiciary Committee, Hearing on the Oversight of the Federal Bureau of Investigation, Feb. 5, 2020 (116th Cong., 2nd sess.)
91. Letter from Representative Madeleine Dean (D-PA) to FBI Director Christopher Wray, February 18, 2020.
92. H.R. 2621, 116th Cong. (2019).
93. Public Law No: 116-92.
94. Katie Mettler and Avi Selk, "GoDaddy—Then Google—Ban Neo-Nazi Site Daily Stormer for Disparaging Charlottesville Victim," *Washington Post*, August 14, 2017, <https://wapo.st/39u6DTX>.
95. Cal. Penal Code § 29180.
96. Cal. Penal Code § 29180.
97. Cal. Penal Code § 29182(b).
98. Cal. Penal Code § 29180(b)(2).
99. Cal. Penal Code § 29180(d)(1).
100. Cal. Penal Code § 30400 et seq.
101. Cal. Penal Code § 30414.
102. Conn. Gen. Stat. § 29-36a.
103. Conn. Gen. Stat. § 53-206j.
104. Conn. Gen. Stat. § 53-206i.
105. Mass. Ann. Laws ch. 140, § 131N.
106. N.J. Stat. § 2C:39-9(d).
107. N.J. Stat. § 2C:39-9(k).
108. N.J. Stat. § 2C:39-9(m).
109. N.J. Stat. § 2C:39-9(l).
110. N.Y. Penal Law §§ 265.50, 265.55.
111. Va. Code Ann. § 18.2-308.5.
112. Wash. Rev. Code Ann. § 9.41.325.
113. Wash. Rev. Code Ann. § 9.41.190.
114. Wash. Rev. Code Ann. § 9.41.190(1)(d).